

# **Matrox Radiant eV-CXP**

Installation and Hardware Reference

Manual no. Y11200-101-0300

January 10, 2014

*Matrox® is a registered trademark of Matrox Electronic Systems Ltd.*

*Microsoft® and Windows®, are registered trademarks of Microsoft Corporation.*

*PCI-X® and PCI Express® are registered trademarks of PCI-SIG. In addition, PCIe is a trademark of PCI-SIG.*

*Belden and Belden 1694A are registered trademarks of Belden, Inc.*

*All other nationally and internationally recognized trademarks and tradenames are hereby acknowledged.*

*© Copyright Matrox Electronic Systems Ltd., 2011-2014. All rights reserved.*

*Limitation of Liabilities: In no event will Matrox or its suppliers be liable for any indirect, special, incidental, economic, cover or consequential damages arising out of the use of or inability to use the product, user documentation or related technical support, including without limitation, damages or costs relating to the loss of profits, business, goodwill, even if advised of the possibility of such damages. In no event will Matrox and its suppliers' liability exceed the amount paid by you, for the product.*

*Because some jurisdictions do not allow the exclusion or limitation of liability for consequential or incidental damages, the above limitation may not apply to you.*

*Disclaimer: Matrox Electronic Systems Ltd. reserves the right to make changes in specifications at any time and without notice. The information provided by this document is believed to be accurate and reliable. However, neither Matrox Electronic Systems Ltd. nor its suppliers assume any responsibility for its use; or for any infringements of patents or other rights of third parties resulting from its use. No license is granted under any patents or patent right of Matrox Electronic Systems Ltd.*

*PRINTED IN CANADA*

# Contents

---

## **Chapter 1: Introduction . . . . . 7**

Matrox Radiant eV-CXP board . . . . .	8
General acquisition features. . . . .	9
Acquisition memory . . . . .	9
Additional functionality . . . . .	9
Data transfer . . . . .	10
Software . . . . .	10
Essentials to get started . . . . .	12
Inspecting the Matrox Radiant eV-CXP package . . . . .	13
Standard items . . . . .	13
Available separately . . . . .	14
Handling components. . . . .	14
Installation . . . . .	15

---

## **Chapter 2: Hardware installation . . . . . 17**

Installing your Matrox Radiant eV-CXP board . . . . .	18
Installing the cable adapter brackets . . . . .	22
Connecting video sources . . . . .	23
Connecting to CoaXPress video input connectors . . . . .	25

---

## **Chapter 3: Using multiple Matrox Radiant eV-CXP boards . . . . 27**

Installation of multiple boards . . . . .	28
Simultaneous image capture from different boards . . . . .	28

---

## **Chapter 4: Matrox Radiant eV-CXP hardware reference . . . . . 29**

Matrox Radiant eV-CXP hardware reference . . . . .	30
--	----

Matrox Radiant eV-CXP acquisition .....	32
Performance .....	33
Power-over-CoaXPress .....	34
Acquisition .....	34
Lookup tables .....	35
CoaXPress trigger signals and control messages .....	35
Auxiliary signals .....	36
Specifications of the auxiliary signals .....	37
Timers .....	38
Trigger .....	38
Rotary decoder .....	39
User signals .....	40
Acquisition memory .....	40
Data conversion .....	41
Host interface .....	43

---

**Appendix A: Glossary..... 45**

Glossary .....	46
----------------	----

---

**Appendix B: Technical information..... 51**

Board summary .....	52
Global information .....	52
Technical features of Matrox Radiant eV-CXP .....	53
Electrical specifications .....	55
Dimensions and environmental specifications .....	56
Connectors on the Matrox Radiant eV-CXP board .....	57
CoaXPress video input connectors .....	58
External auxiliary I/O connectors .....	59

PCIe auxiliary power connector . . . . .	61
LEDs on Matrox Radiant eV-CXP . . . . .	62
CoaXPress LEDs . . . . .	62
Board status LEDs . . . . .	63

---

**Appendix C: Listing of Matrox Radiant eV-CXP boards . . . . . 65**

Key feature changes . . . . .	66
-------------------------------	----

---

**Index**

---

**Regulatory Compliance**

- FCC Compliance Statement
- Industry Canada Compliance Statement
- EU Notice (European Union)
- Directive on Waste Electrical and Electronic Equipment (WEEE)

---

**Limited warranty**



**Chapter**

# 1

## **Introduction**

This chapter briefly describes the features of the Matrox Radiant eV-CXP board, as well as the software that can be used with the board.

## Matrox Radient eV-CXP board

The Matrox Radient eV-CXP board is a high-performance PCIe frame grabber. Matrox Radient eV-CXP supports image capture from high-resolution, high-speed video sources that use the CoaXPRESS (CXP) communication standard.

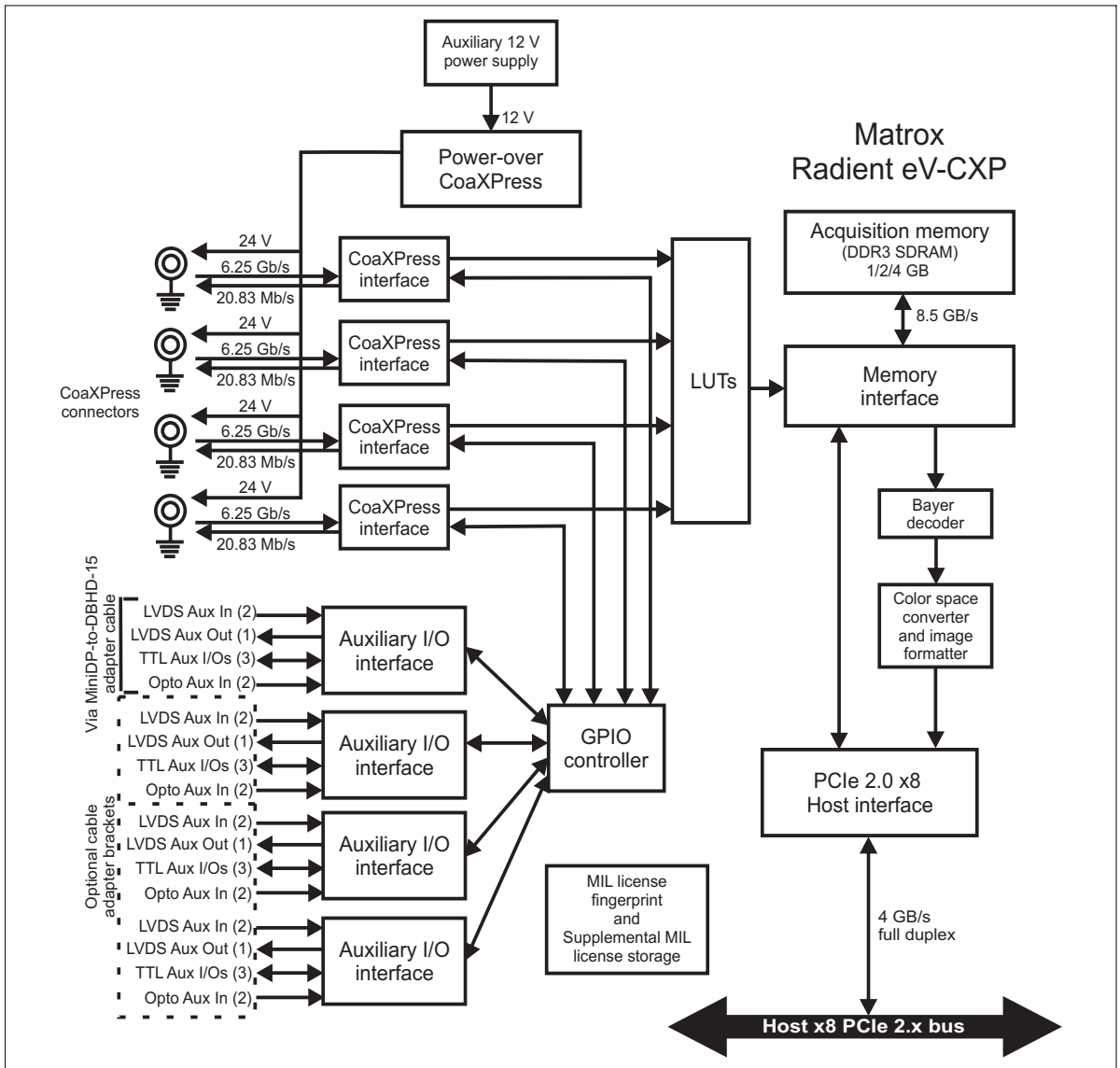

Matrox Radiant eV-CXP supports up to four simultaneous CoaXPress links to video sources that transmit data at different CoaXPress speeds. A CoaXPress link contains all the connections and components to capture from one video source. One link can use 1 to 4 CoaXPress connections; each connection uses one of the 4 independent acquisition paths on Matrox Radiant eV-CXP. The frame grabber can receive image data at a maximum speed of 6.25 Gbits/sec per connection (depending on the cable length). You can increase the speed of the link to a maximum of 25 Gbits/sec by using multiple connections to implement a link (link aggregation). In addition, Matrox Radiant eV-CXP provides up to 13 W of power per CoaXPress connection to any device that supports power-over-CoaXPress (PoCXP).

### **General acquisition features**

Matrox Radiant eV-CXP supports frame and line-scan monochrome and color video sources. The color video sources can be RGB video sources or video sources with a Bayer color filter. Matrox Radiant eV-CXP can decode Bayer color-encoded images and perform color space conversions while transferring the image to the Host.

### **Acquisition memory**

Matrox Radiant eV-CXP is equipped with 1, 2, or 4 Gbytes of DDR3 SDRAM acquisition memory, which is used to store acquired images. This memory is accessed through the memory interface. The memory interface has multiple input ports and a data transfer rate of up to 8.5 Gbytes/sec.

### **Additional functionality**

In addition to the core video capture capabilities, Matrox Radiant eV-CXP incorporates a variety of features to simplify overall system integration. These features include:

- **Color space converter and image formatter.** This can convert data as it is being transferred to the Host. It can convert 8- or 16-bit monochrome or 24- or 48-bit packed BGR data to monochrome, packed BGR, packed BGRa, planar RGB, or YUV (YUYV) format. In addition, it can flip or subsample data sent to the Host.
- **Bayer decoder.** This can convert Bayer-encoded data to RGB. The following Bayer patterns are supported: GRBG, GBRG, BGGR, and RGGB.

- **Auxiliary, multi-purpose signals.** These are non-video signals that can support one or more functionalities (for example, trigger input or timer output), depending on the auxiliary signal. Matrox Radiant eV-CXP features 32 auxiliary signals that are independent of the acquisition path, accessible via four DBHD-15 connectors. Each DBHD-15 connector has 3 TTL configurable auxiliary inputs/outputs, 2 LVDS auxiliary inputs, 1 LVDS auxiliary output, and 2 opto-isolated auxiliary inputs.
- **Integrated rotary decoders.** These can decode quadrature input received from a rotary encoder.

### **Data transfer**

Your Matrox Radiant eV-CXP can send data to the Host at a maximum theoretical transfer rate of 4.0 Gbytes/sec. Optimum conditions for high speed transfer include using the board in a PCIe 2.x slot with 8 active lanes, using a 256-byte payload. DMA write performance is chipset and computer dependent, and is slightly affected by the image size and alignment in Host memory (frame start address and line pitch).

To measure the effective available bandwidth of the PCIe slot in your computer with the Matrox Radiant eV-CXP board, Matrox provides the RadiantCXPBench tool; the tool is integrated in the MILConfig utility, which is shipped with software that supports Matrox Radiant eV-CXP (for example, MIL).

## **Software**

---

To operate your Matrox Radiant eV-CXP, you can use one or more Matrox Imaging software products that supports the board. These are the Matrox Imaging Library (MIL) and its derivatives (for example, MIL-Lite and Matrox Intellicam). All Matrox software is supported under Windows; MIL is also supported under Linux when using Matrox Radiant eV-CXP. Consult your software manual for supported versions of these operating systems.

### **MIL**

MIL is a high-level programming library with an extensive set of optimized functions for image capture, processing, analysis, transfer, compression, display, and archiving. Image processing operations include point-to-point, statistical, spatial filtering, morphological, geometric transformation, and FFT operations. Analysis operations support calibration, are performed with sub-pixel accuracy, and include pattern recognition (normalized grayscale correlation and Geometric Model Finder), blob analysis, edge extraction and analysis, measurement, image

registration, metrology, character recognition (template-based and feature-based), code recognition and verification (1D, 2D and composite code types), bead (continuous strips of material) inspection, 3D reconstruction, and color analysis.

MIL applications are easily ported to new Matrox hardware platforms and can be designed to take advantage of multi-processing and multi-threading environments.

**MIL-Lite**

MIL-Lite is a subset of MIL. It includes all the MIL functions for image acquisition, transfer, display control, and archiving. It also allows you to perform processing operations that are typically useful to pre-process grabbed images.

**Matrox Intellicam**

Matrox Intellicam is an interactive Windows program that allows for fast video source interfacing and provides interactive access to all the acquisition features of your Matrox board. Matrox Intellicam also has the ability to create custom digitizer configuration format (DCF) files, which MIL and its derivatives use to interface to specific non-standard video sources. Matrox Intellicam is included with all Matrox Imaging software products.

## **Essentials to get started**

---

To begin using your Matrox Radiant eV-CXP, you must have a computer with the following:

- An available conventional x8 (or x16) PCIe 1.x or 2.x slot<sup>\*</sup>. Note that a PCIe 2.x slot will ensure the fastest possible transfer of data to the Host.
- Processor with an Intel 32-bit or 64-bit architecture, or equivalent.
- A relatively up-to-date PCIe chipset. A chipset that supports the PCIe 2.x standard is preferable. The list of platforms that are known to be compatible with Matrox Radiant eV-CXP is available on the Matrox website, under the board's PC compatibility list.
- MIL or one of its derivatives. This software should be installed after you install your board.

Matrox does not guarantee compatibility with all computers that have the above specifications. Please consult with your local Matrox Imaging representative, local Matrox Imaging sales office, the Matrox web site, or the Matrox Imaging Customer Support Group at headquarters before using a specific computer.

Consult your software package for other computer requirements (for example, operating system and memory requirements).

---

\*. Note that you can also install Matrox Radiant eV-CXP in a x4 PCIe slot that has a mechanical x8 connector; however, the maximum transfer rate between Matrox Radiant eV-CXP and the Host is reduced by 50%.

## Inspecting the Matrox Radiant eV-CXP package

---

You should check the contents of your Matrox Radiant eV-CXP package when you first open it. If something is missing or damaged, contact your Matrox representative.

### Standard items

You should receive the following items:

- The Matrox Radiant eV-CXP board.

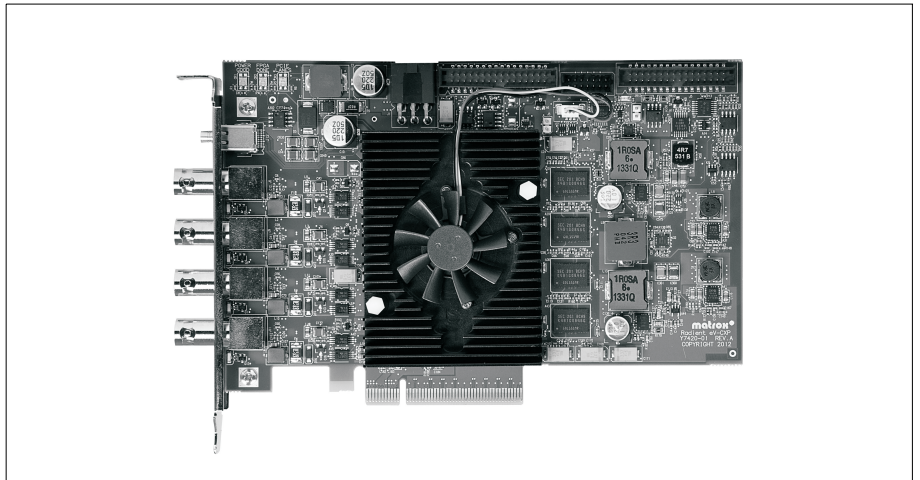

- A MiniDP-to-DBHD-15 adapter cable. The cable has a Mini DisplayPort (MiniDP) connector at one end, and a DBHD-15 connector at the other end.



### Available separately

You might have also ordered one or more of the following:

- A DBHD-15 cable adapter bracket, equipped with two DBHD-15 auxiliary I/O connectors.

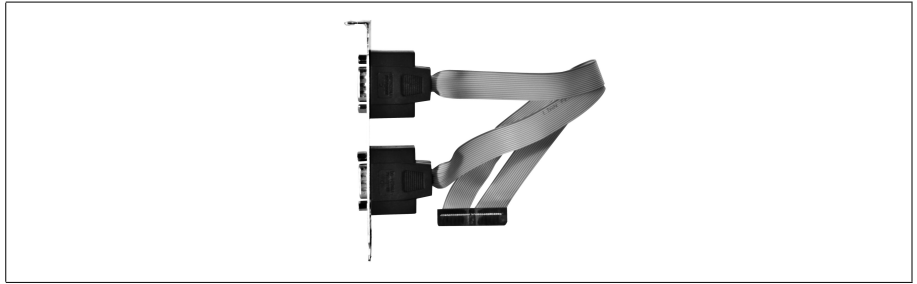

- MIL or MIL-Lite. Matrox Intellicam is included with both of these software packages.
- ❖ If needed, you can purchase high-quality, 75  $\Omega$  coaxial cables from the video source manufacturer, Belden Inc., or other third parties.

### Handling components

The electronic circuits in your computer and the circuits on your Matrox Radiant eV-CXP are sensitive to static electricity and surges. Improper handling can seriously damage the circuits. Be sure to drain static electricity from your body by touching a metal fixture (or ground) before you touch any electronic component. In addition, do not let your clothing come in contact with the circuit boards or components.

### Warning

Before you add or remove devices from your computer, always **turn off** the power to your computer and all peripherals.

## Installation

---

The installation procedure consists of the following steps:

1. Complete the hardware installation procedure described in *Chapter 2: Hardware installation*.
2. Complete the software installation procedure described in the documentation accompanying your software package.

### More information

For information on using multiple Matrox Radiant eV-CXP boards, refer to *Chapter 3: Using multiple Matrox Radiant eV-CXP boards*.

For in-depth hardware information, refer to *Chapter 4: Matrox Radiant eV-CXP hardware reference*; whereas for a summary of this information, as well as environmental and electrical specifications, and connector pinout descriptions, see *Appendix B: Technical information*.

This manual occasionally makes reference to a MIL-Lite function. However, anything that can be accomplished with MIL-Lite can also be accomplished with MIL.

### Need help?

If you experience problems during installation or while using this product, refer to the support page on the Matrox Imaging web site: [www.matrox.com/imaging/support](http://www.matrox.com/imaging/support). This page provides answers to frequently asked questions, as well as offers registered customers additional ways of obtaining support.

If your question is not addressed and you are currently registered with the MIL maintenance program, you can contact technical support. To do so, you should first complete and submit the online Technical Support Request Form, accessible from the above-mentioned page. Once the information is submitted, a Matrox support agent will contact you shortly thereafter by email or phone, depending on the problem.



**Chapter**

# 2

## **Hardware installation**

This chapter explains how to install your Matrox Radiant eV-CXP board in your computer.

## Installing your Matrox Radiant eV-CXP board

Before you install your Matrox Radiant eV-CXP board, some precautionary measures must be taken. Turn off the power to your computer and its peripherals, and drain static electricity from your body (by touching a metal part of the computer chassis).

### Important

- ❖ Note that your board should be installed before you install your software.

Proceed with the following steps to install your board:

1. Remove the cover from your computer; refer to your computer's documentation for instructions.
2. Check that you have an empty x8 (or x16) PCIe 1.x or 2.x slot in which to install your Matrox Radiant eV-CXP\*. Note that a PCIe 2.x slot will ensure the fastest possible transfer of data to the Host.

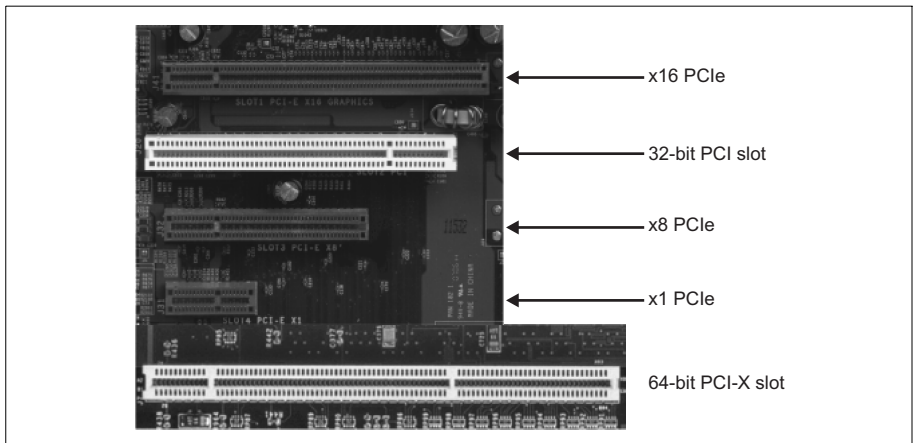

---

\*. Note that you can also install Matrox Radiant eV-CXP in a x4 PCIe slot that has a mechanical x8 connector; however, the maximum transfer rate between Matrox Radiant eV-CXP and the Host is reduced by 50%.

Matrox Radiant eV-CXP might drop frames if the PCIe slot does not have at least 8 active lanes (for example, if the board is connected to a x8 PCIe slot that has only four active lanes<sup>\*</sup>). Verify with your motherboard manufacturer to find out whether your motherboard works efficiently with a x8 PCIe board, such as Matrox Radiant eV-CXP.

If you need to install the DBHD-15 cable adapter brackets, you will need an additional slot for each cable adapter bracket. These slots need not be adjacent to the Matrox Radiant eV-CXP board. In addition, the cable adapter brackets do not plug into a slot's connector; they attach only to the back of the computer's chassis.

- ❖ Note that the external auxiliary I/O connectors on the cable adapter brackets are panel mount connectors. If you don't want to occupy an entire slot for each additional bracket, you can punch out two holes in the computer chassis, and then screw the connectors in the holes.

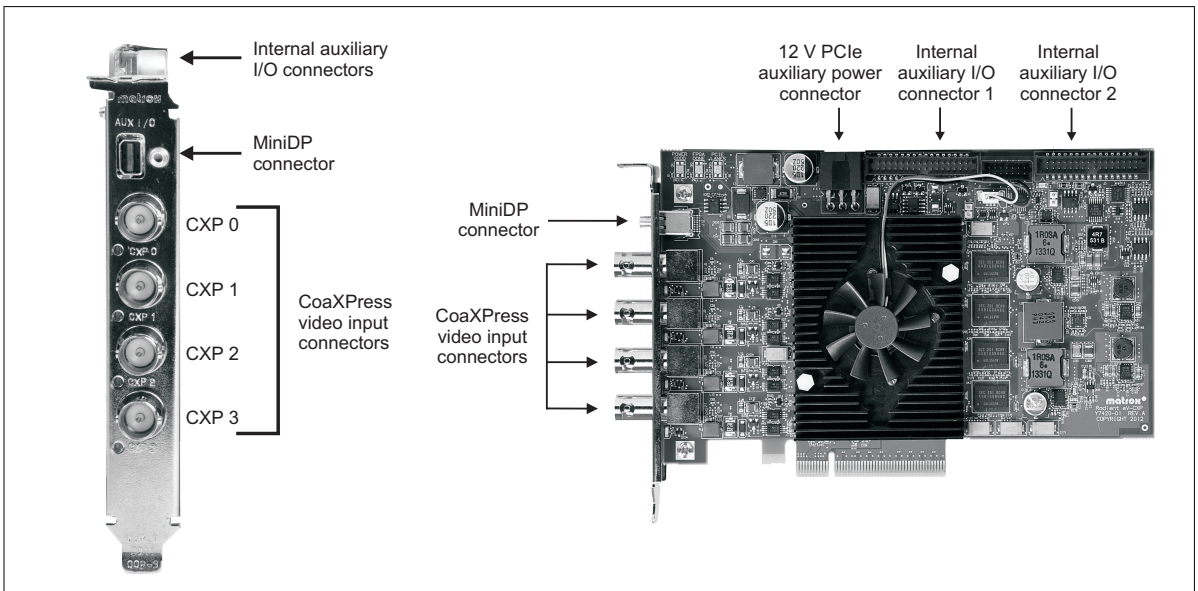

\*. After installing the board, you can verify in software the number of PCIe lanes that are currently active, using the MIL-Lite function `MsysInquire()` with `M_PCIE_NUMBER_OF_LANES`.

3. If there is a metal plate at the back of the selected slots, remove it. Keep the screw from the top of the plate to anchor your board and cable adapter brackets once they are installed.
4. Position your Matrox Radiant eV-CXP board in the selected PCIe slot. Align the CoaXPress connectors with the opening at the back of the slot, and move the board until the connectors pass through the opening.

### **Important**

When installing your Matrox Radiant eV-CXP board in a x16 PCIe slot, special care must be taken to avoid damaging the board. Some x16 PCIe slots have a connector with a retainer. You should avoid touching the latch of this retainer with the board. Alternatively, you can remove the latch from the retainer.

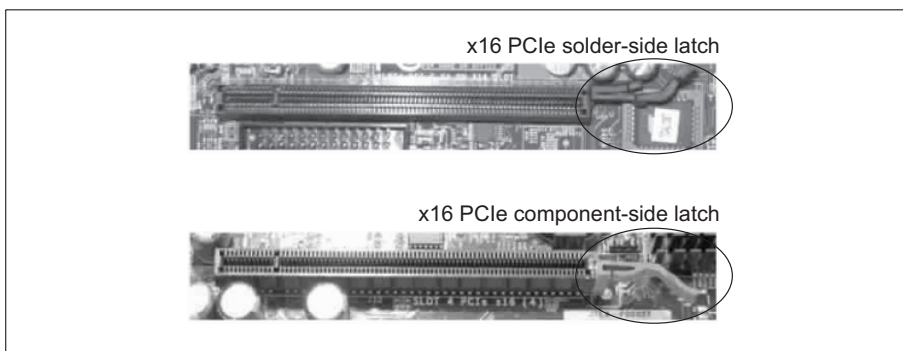

5. Once all four CoaXPress input connectors are in the opening in the chassis, press the board firmly but carefully straight down into the connector of the slot.
6. Anchor the board using the screw that you removed in step 3.
7. Connect the PCIe power cable from your computer's 12 V power supply to the PCIe auxiliary power connector on Matrox Radiant eV-CXP.
  - ❖ You only need to connect the auxiliary power if you are using PoCXP-compliant video sources.
8. If required, install the cable adapter brackets, as described in the section *Installing the cable adapter brackets*, later in this chapter.
9. Attach your video sources, as described in the section *Connecting video sources*, later in this chapter.

10. Turn on your computer.
  - ❖ When you boot your computer under Windows, Windows' Plug-and-Play system will detect a new Multimedia Video Device and you will be asked to assign it a driver. At this point, you should click on **Cancel**.

Under Windows and Linux, the driver will be installed during the installation of Matrox Radiant eV-CXP software.

11. Disable active state power management (ASPM) for PCIe devices, to maximize the performance of Matrox Radiant eV-CXP. In the BIOS, disable all ASPM (or equivalent) settings (typically accessible from the **Power management** submenu of the **Advanced Configurations** menu). In addition, if the operating system has an **ASPM for PCIe devices** option, disable this option as well. For example, under Microsoft Windows 7, open the **Power Options** dialog box from the Windows Control Panel. For the currently selected power plan, click on **Change Plan Settings** and then click on **Change Advanced Power Settings**. In the presented dialog, expand **PCI Express**, and then expand **Link State Power Management** and set it to **Off**.
12. Under Microsoft Windows, set the power plan option to high performance to maximize the performance of Matrox Radiant eV-CXP and minimize the possibility of dropped frames. For example, under Microsoft Windows 7, open the **Power Options** dialog box from the Windows Control Panel and set the power plan option to **High Performance**.

## Installing the cable adapter brackets

---

To install the cable adapter brackets, proceed with the following steps:

1. Make sure that your Matrox Radiant eV-CXP board is fastened to the computer chassis.
2. Attach the two cable adapter brackets to the internal auxiliary I/O connectors on the Matrox Radiant eV-CXP board. When attaching the flat ribbon cables of the adapter brackets, position each cable so that the black wire is on the same side as the bracket of the Matrox Radiant eV-CXP board.

Note that the two cable adapter brackets are physically identical. For naming purposes, the cable adapter bracket that you connect to internal auxiliary I/O connector 1 is the primary cable adapter bracket. The secondary cable adapter bracket is the cable adapter bracket that you connect to internal auxiliary I/O connector 2.

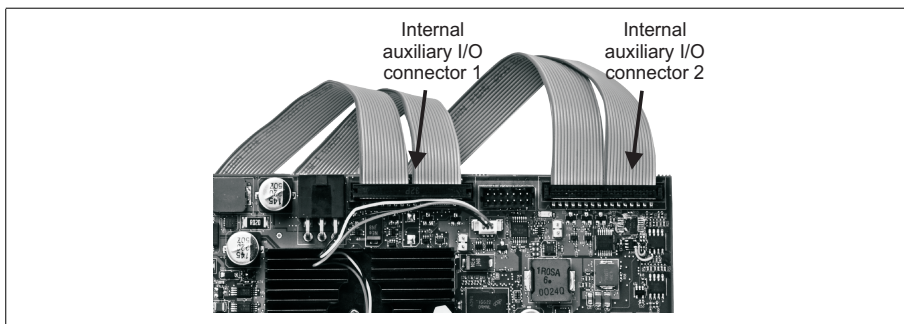

3. Slide the bracket of the cable adapter bracket into the opening at the back of the selected slot.
4. Anchor the bracket to the chassis using the screw that you removed in the previous section.

Note that the external auxiliary I/O connectors on the cable adapter brackets are panel mount connectors. If you don't want to occupy an entire slot for each additional bracket, you can punch out two holes in the computer chassis, and then screw the connectors in the holes.

## Connecting video sources

The Matrox Radiant eV-CXP board has the following connectors on its bracket:

- **Four CoaXPress video input connectors (BNC).** Used to receive video streams from the video sources. These connectors are also used to transmit and receive CoaXPress trigger signals, as well as control and acknowledgement messages.
- **Mini DisplayPort (MiniDP) connector.** Used to connect the MiniDP-to-DBHD-15 adapter cable. The DBHD-15 connector on the adapter cable is called external auxiliary I/O connector 0. This connector is used to transmit and receive auxiliary signals.

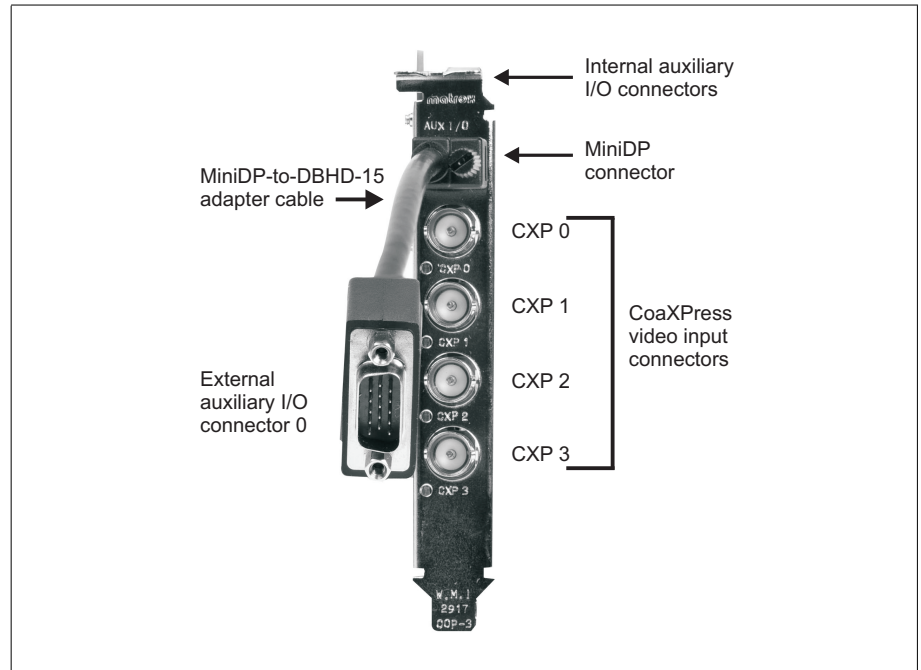

To access the signals of the internal auxiliary I/O connectors, you can install up to two cable adapter brackets. They each have two connectors that are named based on the internal auxiliary I/O connector to which their cable adapter bracket is attached.

- External auxiliary I/O connectors 1, 2, and 3 (panel mount DBHD-15). Each used to transmit and receive auxiliary signals.

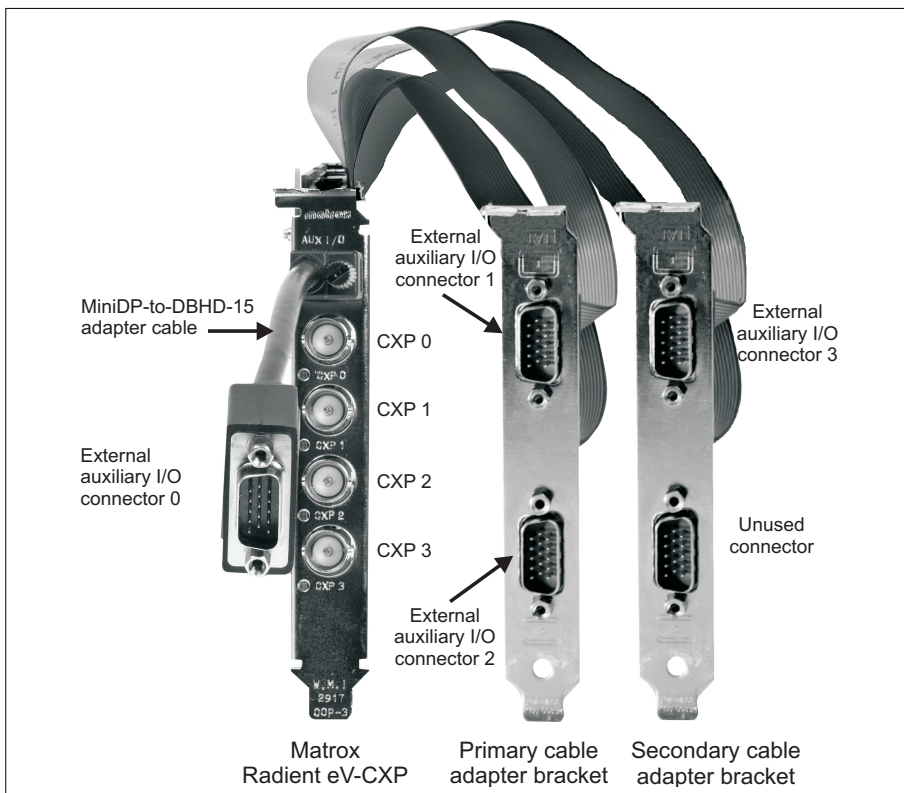

Note that the primary cable adapter bracket is the bracket that you attach to internal auxiliary I/O connector 1, and the secondary cable adapter bracket is the bracket that you attach to internal auxiliary I/O connector 2.

### Connecting to CoaXPress video input connectors

When attaching video sources to your Matrox Radiant eV-CXP, you must use 75  $\Omega$  coaxial cables with standard BNC connectors. For the best performance, it is recommended that you use high-quality cables, such as Belden 1694A cables.

Note that a video source with multiple cables will have one cable denoted as the master connection (for example, with an arrow marked on the cable) and the others as extension connections. Keep track of the video input connector to which you attach the master connection because you will need this information when using MIL-Lite (`MdigAlloc()` with `M_DEVn`) to identify the video source.

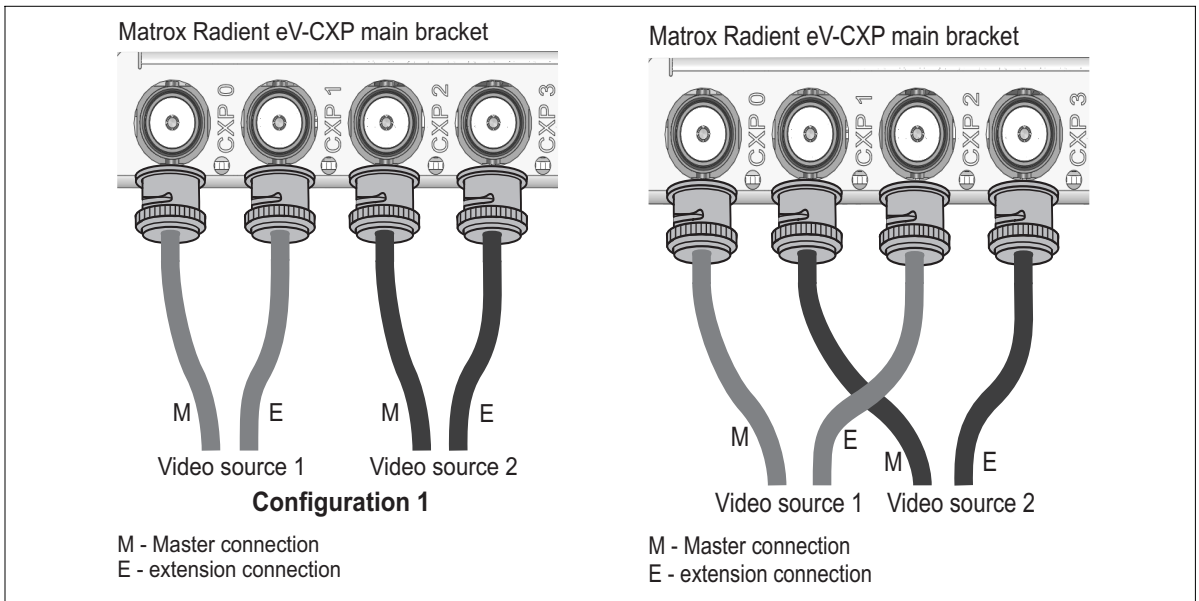

Matrox Radiant eV-CXP communicates with the video sources to identify which video source is connected to which input connectors.

- ❖ Note that if you are using more than one coaxial cable to connect to the same video source, the cables you choose must be of the same type and length.

The length of cable that you choose will affect the maximum data transmission rate. In general, for lengths greater than 40 m, the longer your cables, the lower the maximum possible bit rate. For example, using high-quality, 100 m cables, the maximum possible bit rate is 3.125 Gbits/sec. Another factor that affects the bit rate is the quality of the cables that you choose.

## CoaXPress LEDs

The four CoaXPress LEDs on the main bracket identify the state and activity of connected devices.

The typical sequence of LED states is as follows:

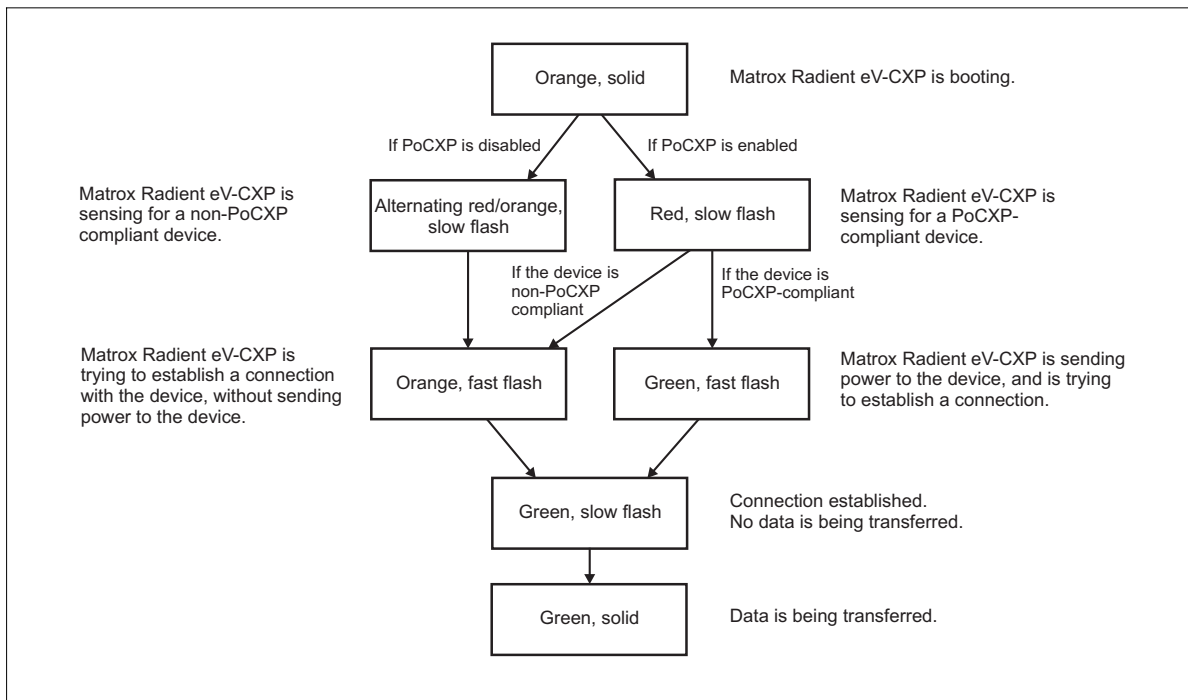

### Important

If the sequence of LED states on your Matrox Radient eV-CXP is different from this sequence, there could be a problem with your device or with data transfer. Please refer to the *CoaXPress LEDs* section in *Appendix B: Technical information* for the complete list of possible LED states.

**Chapter**

# 3

## **Using multiple Matrox Radiant eV-CXP boards**

This chapter explains how to use multiple Matrox Radiant eV-CXP boards.

## Installation of multiple boards

---

You can install and use multiple Matrox Radiant eV-CXP boards in one computer.

Install each additional Matrox Radiant eV-CXP board as you installed the first board (refer to *Chapter 2: Hardware installation*). The number of Matrox Radiant eV-CXP boards that you can install is primarily dependent on the number of physical slots in your computer, and your BIOS; your BIOS establishes how many PCIe devices can be mapped to the PCIe memory space of your computer.

Using MIL-Lite, you have to allocate a MIL system for each board and allocate the resources of each MIL system. For more information, see `MsysAlloc()` with `M_SYSTEM_RADIENTCXP` in the MIL Reference.

## Simultaneous image capture from different boards

---

In addition to capturing images from multiple video sources with a single Matrox Radiant eV-CXP board, you can also simultaneously capture images from video sources attached to multiple Matrox Radiant eV-CXP boards. Note that the number of video sources from which you can simultaneously capture images is limited by the PCIe chipset on your computer.

The use of a high performance PCIe chipset is necessary to sustain PCIe transfers to Host memory. Ideally, a PCIe 2.x chipset should be used. A PCIe 2.x Host bus will optimize the speed of data transmission, and will minimize data loss. The list of platforms that are known to be compatible with Matrox Radiant eV-CXP is available on the Matrox web site, under the board's compatibility list.

To measure the effective available bandwidth of the PCIe slot in your computer with the Matrox Radiant eV-CXP board, you can use the `RadiantCXPBench` tool integrated in the `MILConfig` utility. As a reference point, capturing from a 2K x 2K, 8-bit, 60 frames/sec video source will require a minimum bandwidth of 240 Mbytes/sec, plus an additional bandwidth margin of approximately 20%, for a bandwidth of 288 Mbytes/sec.

**Chapter**

# 4

## **Matrox Radiant eV-CXP hardware reference**

This chapter explains the architecture, features, and modes of the Matrox Radiant eV-CXP hardware.

## Matrox Radiant eV-CXP hardware reference

---

This chapter provides information on the Matrox Radiant eV-CXP hardware. It covers the architecture, features, and modes of the board's acquisition section. In addition, the chapter covers the Matrox Radiant eV-CXP hardware related to the formatting and transfer of data. A summary of the features of Matrox Radiant eV-CXP, as well as pin assignments for the various connectors, can be found in *Appendix B: Technical information*.

### Acquisition path

This manual uses the term acquisition path to refer to a path that has the capability to, for example, capture a component or stream of the video input signal. The term *independent acquisition path* is used to refer to an acquisition path that can, if required, acquire data from a video source independently from another such path on the same frame grabber. On Matrox Radiant eV-CXP, each CoaXPress connection in a CoaXPress link uses a different acquisition path.

### Digitizer

MIL-Lite uses the concept of a MIL digitizer to represent the acquisition path(s) with which to grab from one input source (one CoaXPress link) of the specified type. When several MIL digitizers are allocated, their device number along with their DCF identify if they represent the same path(s) (but perhaps for a different input format) or independent path(s) for simultaneous acquisition.

### Digitizer configuration format

To program the acquisition section, allocate a MIL digitizer using **MdigAlloc()** with an appropriate DCF (supplied or created) and digitizer device number. If you find a DCF file that is suitable for your video source, but you need to adjust some of the more common settings, you can do so directly, without adjusting the file, using the appropriate MIL-Lite function. For more specialized adjustments, use the Matrox Intellicam program to adjust the DCF file.

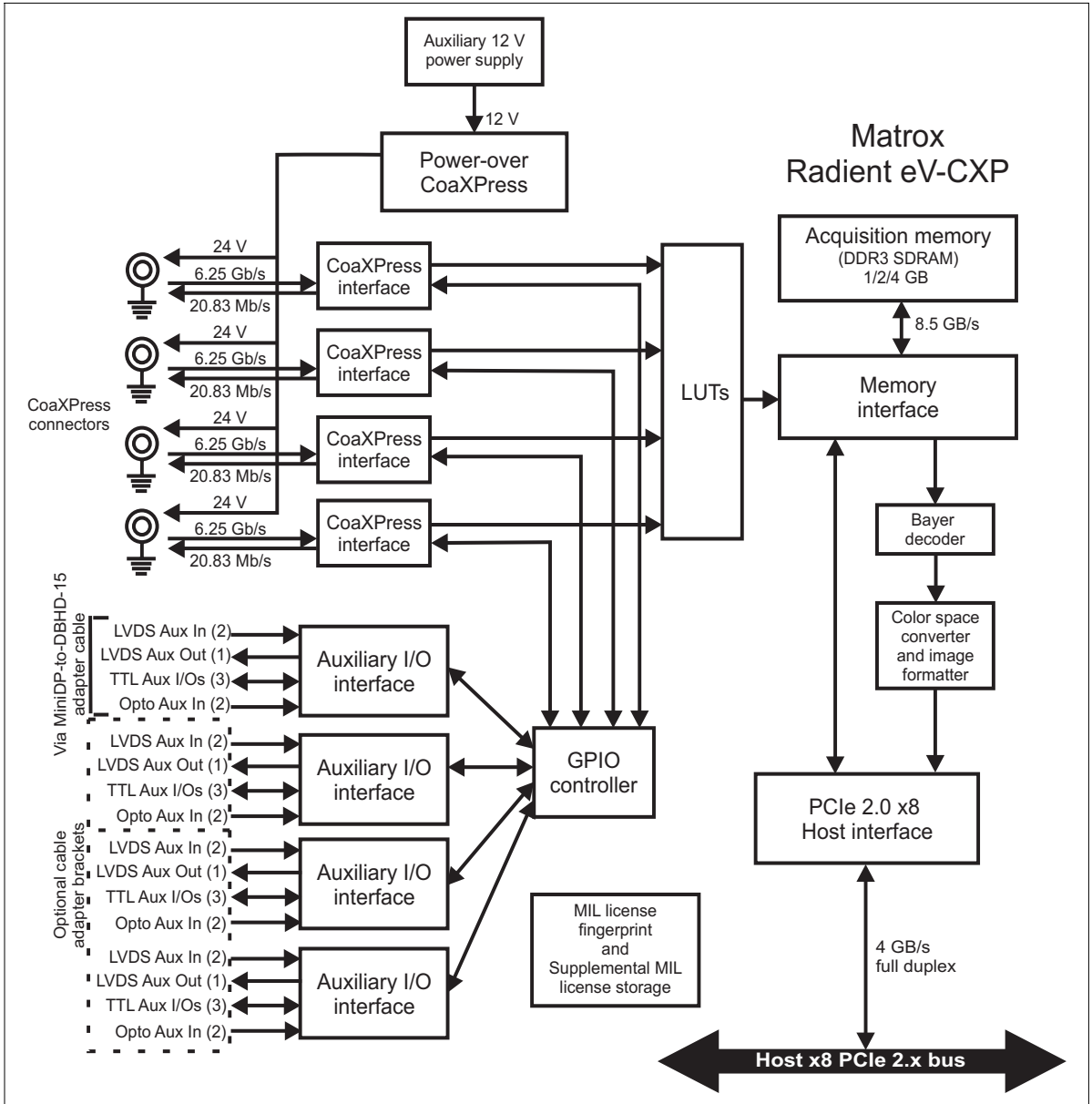

## **Matrox Radiant eV-CXP acquisition**

---

Matrox Radiant eV-CXP can capture video from digital video sources compliant with the CoaXPress standard 1.0 specification. Matrox Radiant eV-CXP has four independent acquisition paths (CoaXPress connections). When a video source is connected to Matrox Radiant eV-CXP, the board communicates with the video source to determine the rate at which data will be transferred. Matrox Radiant eV-CXP can provide power-over-CoaXPress to attached video sources.

For each video source connected to the board, Matrox Radiant eV-CXP supports a CoaXPress trigger input signal and a CoaXPress trigger output signal, which are used to communicate exclusively with the video source. To communicate with other third-party devices, Matrox Radiant eV-CXP provides 32 auxiliary signals. Auxiliary input signals can be rerouted to the CoaXPress trigger output signal and the CoaXPress trigger input signal can be rerouted to auxiliary output signals.

Matrox Radiant eV-CXP supports monochrome, RGB color, and Bayer color-encoded acquisition. The board can perform color-conversion, flipping, and image subsampling.

**Performance**

The performance of each connection between Matrox Radiant eV-CXP and the video source is as follows:

	Maximum
Number of pixels / line	64 K
Number of lines / frame	64 K
Downlink bit rate (per connection)	6.25 Gbits/sec
Uplink bit rate (per connection)	0.02 Gbits/sec

The maximum data transmission rate that you can achieve depends on the length of your coaxial cable, the quality of the cable, as well as the type of PCIe slot to which you connect your Matrox Radiant eV-CXP.

**Effect of cable length**

For lengths greater than 40 m, the longer the cables, the lower the maximum possible bit rate. High-quality cables, such as Belden 1694A cables, will allow for the highest possible bit rates. The table below outlines the bit rates that you can expect to achieve at certain lengths, using Belden 1694A cables, as well as the bit rates possible when connecting to a single video source using link aggregation (2, 3, and 4 cables).

Length	Number of connections (cables connected to the video source)	Maximum bit rate (speed)
130 m	1	1.25 Gbits/sec
100 m	1	3.125 Gbits/sec
40 m	1	6.25 Gbits/sec
40 m	2	12.5 Gbits/sec
40 m	3	18.75 Gbits/sec
40 m	4	25.0 Gbits/sec

**Effect of the type of PCIe slot**

A PCIe 2.x slot supports a higher data transmission rate than a 1.x slot. A by-four (x4) PCIe slot will lower the data rate by half, when compared to a by-eight (x8) PCIe slot of the same base specification (1.x or 2.x). While transferring data to the Host, these factors will reduce the maximum transmission rate as shown in the table.

Reduction in maximum data transmission rate, as it depends on the type of PCIe slot	x8 PCIe slot	x4 PCIe slot (with mechanical x8 connector)
PCIe base specification 1.x	50%	25%
PCIe base specification 2.x	100%	50%

**Power-over-CoaXPress**

Matrox Radiant eV-CXP supports power-over-CoaXPress (PoCXP) compliant video sources, and non-PoCXP compliant video sources. When Matrox Radiant eV-CXP is connected to a proper auxiliary 12 V power supply, the CoaXPress standard is configured to provide up to 13 W per connection, at a nominal voltage of 24 V, to the connected device.

Matrox Radiant eV-CXP detects whether the video source is PoCXP-compliant. When connecting to non-PoCXP compliant video sources, Matrox Radiant eV-CXP has appropriate circuitry to ensure that no power is transmitted. To manually disable the PoCXP circuitry and ensure that no power is sent to the device, you can use the MIL-Lite function `MdigControl()`.

Matrox Radiant eV-CXP is also equipped with an overcurrent protection mechanism and a resettable fuse that can sustain a current of 1 A.

**Acquisition**

Matrox Radiant eV-CXP accepts 8-, 10-, 12-, 14- and 16-bit video data. All data is transmitted in packets over a CoaXPress link.

The Matrox Radiant eV-CXP CoaXPress interface is responsible for buffering incoming data before it is written to memory, as well as assembling and disassembling packets from the video sources. Video sources can be frame or line-scan video sources.

## Lookup tables

Matrox Radiant eV-CXP has on-board lookup tables (LUTs) that can be used to precondition input data at acquisition time, before it is stored in memory.

There is one LUT palette available per acquisition path (CoaXPress connection) for 8- and 10-bit monochrome or color data; for color data, all color components map through the same LUT palette. For 12-bit monochrome or color data, all acquisition paths use the same palette; for color data, the same palette is used for all color components. For 14- and 16-bit data, a transparent LUT palette is used. The LUTs are programmed using the MIL-Lite function `MdigControl()` with `M_LUT_ID`.

## CoaXPress trigger signals and control messages

---

To communicate exclusively with the video source(s), Matrox Radiant eV-CXP supports CoaXPress trigger signals and control messages. Trigger packets, which are sent and received between the video source(s) and the board, are virtually represented as trigger signals. Control messages constitute the basic communication mechanism between the video source(s) and the board.

For each video source connected to the board, Matrox Radiant eV-CXP supports a CoaXPress trigger input signal and a CoaXPress trigger output signal. A CoaXPress trigger input signal can be used to start a timer, or to trigger other off-board devices (via the auxiliary output signals). A CoaXPress trigger output signal can be sent from the board to a video source to initiate image acquisition or to optionally control the exposure time.

To send a trigger output signal to the camera, you use the MIL-Lite function `MdigControl()` with `M_IO_SOURCE + M_TL_....`. To set the CoaXPress trigger input signal as the signal used to trigger the grab, use `MdigControl()` with `M_GRAB_TRIGGER_SOURCE` set to `M_TL_...`

For more information on how to use the auxiliary input and output signals, refer to the following *Auxiliary signals* section.

## Auxiliary signals

The auxiliary signals of Matrox Radiant eV-CXP are acquisition path independent and can be used to initiate on-board events (inputs) or can be transmitted to third-party devices (outputs). You can also reroute a CoaXPress trigger input signal to another device via an auxiliary output signal.

The following table summarizes the auxiliary functionality that Matrox Radiant eV-CXP supports using its auxiliary I/O signals. The table also documents the MIL constants to use. Note that an auxiliary input signal can also be re-routed to a video source via the CoaXPress trigger output signal; an auxiliary input signal cannot be re-routed to an auxiliary output signal.

	TTL Aux I/O												OPTO Aux In								LVDS Aux In								LVDS Aux Out			
	Aux I/O Connector												Aux I/O Connector								Aux I/O Connector								Aux I/O Connector			
	0			1			2			3			0	1	2	3	0	1	2	3	0	1	2	3	0	1	2	3				
<b>M_AUX_IO<math>n^*</math></b>	4	5	6	12	13	14	20	21	22	28	29	30	0	1	8	9	16	17	24	25	2	3	10	11	18	19	26	27	7	15	23	31
<b>Functionality</b>	AUX(TRIG)_TTL_IO_4	AUX(TRIG)_TTL_IO_5	AUX(TRIG)_TTL_IO_6	AUX(TRIG)_TTL_IO_12	AUX(TRIG)_TTL_IO_13	AUX(TRIG)_TTL_IO_14	AUX(TRIG)_TTL_IO_20	AUX(TRIG)_TTL_IO_21	AUX(TRIG)_TTL_IO_22	AUX(TRIG)_TTL_IO_28	AUX(TRIG)_TTL_IO_29	AUX(TRIG)_TTL_IO_30	AUX(TRIG)_OPTO_IN0	AUX(TRIG)_OPTO_IN1	AUX(TRIG)_OPTO_IN8	AUX(TRIG)_OPTO_IN9	AUX(TRIG)_OPTO_IN16	AUX(TRIG)_OPTO_IN17	AUX(TRIG)_OPTO_IN24	AUX(TRIG)_OPTO_IN25	AUX(TRIG)_LVDS_IN2	AUX(TRIG)_LVDS_IN3	AUX(TRIG)_LVDS_IN10	AUX(TRIG)_LVDS_IN11	AUX(TRIG)_LVDS_IN18	AUX(TRIG)_LVDS_IN19	AUX(TRIG)_LVDS_IN26	AUX(TRIG)_LVDS_IN27	AUX(EXP)_LVDS_OUT7	AUX(EXP)_LVDS_OUT15	AUX(EXP)_LVDS_OUT23	AUX(EXP)_LVDS_OUT31
<b>Timer (M_TIMER<math>n^*</math>)</b>	1/2/3/4	1/2/3/4	1/2/3/4	1/2/3/4	1/2/3/4	1/2/3/4	1/2/3/4	1/2/3/4	1/2/3/4	1/2/3/4	1/2/3/4	1/2/3/4																	1/2/3/4	1/2/3/4	1/2/3/4	1/2/3/4
<b>Trigger controller affected by input signal</b>	†	†	†	†	†	†	†	†	†	†	†	†	†	†	†	†	†	†	†	†	†	†	†	†	†	†	†	†				
<b>Bit of quadrature input‡</b>	0			1			2			3											0	1										
<b>Decoder</b>																																
<b>User output (bit of static-user-output register M_USER_BIT<math>n^*</math>)</b>	4	5	6	12	13	14	20	21	22	28	29	30																	7	15	23	31

\*. MIL constant, where  $n$  corresponds to the number in the row. The functionalities that can be routed onto these auxiliary signals are shared across all acquisition paths.

†. Unlike some other Matrox frame grabbers, there is no limit to the number of events that can be triggered simultaneously using the auxiliary input signals, nor is there a restriction on which auxiliary signal can be used to trigger an event.

‡. A rotary encoder with quadrature output transmits a two-bit code. The table entries 0 and 1, therefore, denote bit position.

## Specifications of the auxiliary signals

Matrox Radiant eV-CXP has auxiliary signals in the following formats:

Signal format	Total # of signals	
	Without cable adapter brackets	With two cable adapter brackets attached
TTL auxiliary input or output (I/O) signals	3	12
Opto-isolated auxiliary input signals	2	8
LVDS auxiliary input signals	2	8
LVDS auxiliary output signals	1	4
Total number of auxiliary signals	8	32

When you route an external signal (not a CoaXPress signal) to an auxiliary signal or vice versa, verify that the external signal meets the electrical specifications of the auxiliary signal.

When an auxiliary input signal is received in TTL format directly, it will be clamped at a maximum of 5.7 V and at a minimum of -0.7 V to protect the input buffer. Typically, the signal should have a maximum of 5 V and a minimum of 0 V. A signal over 2 V is considered high, while anything less than 0.8 V is considered low.

The opto-isolated auxiliary input signals pass through an opto-coupler, a device that protects the board from outside surges and different ground levels, and allows the frame grabber to be totally isolated. The voltage difference across the positive and negative components of the signal must be between 4.71 V and 9.165 V for logic high, and between -5.0 V and 0.8 V for logic low.

You can set the direction of an auxiliary I/O signal using the MIL-Lite function `MdigControl()` with `M_AUX_SIGNAL_MODE`.

You can set up the auxiliary signals in the DCF. Alternatively, for most commonly used functionalities, you can configure the auxiliary signals using the MIL-Lite function `MdigControl()` (for example, with `M_IO...`, `M_GRAB_TRIGGER...`, `M_TIMER...`, or `M_ROTARY_ENCODER...`).

## Timers

Matrox Radient eV-CXP has four 16-bit timers, which operate on a 125 MHz internal clock or the output of another timer set in continuous mode.

Timer output signals allow you to control the exposure time and other external events related to the video source (such as a strobe). A timer output signal can be output on any of the auxiliary output signals or auxiliary I/O signals in output mode. A timer output can also be sent to a video source via the CoaXPress trigger output signal.

To route a timer output on an auxiliary signal, use the MIL-Lite function `MdigControl()` with `M_IO_SOURCE + M_AUX_IOn` set to `M_TIMERm`. To set up a timer, use `MdigControl()` with `M_TIMER_....`

## Trigger

You can use any of the auxiliary input signals (or auxiliary I/O signals in input mode) or the CoaXPress trigger input signal as a trigger. A trigger signal can be used to initiate image acquisition, or prompt an on-board event.

### Timing requirements

When you use an auxiliary input signal as a trigger, the pulse width of the signal must be at least 16 nsec (2 clock periods at 125 MHz).

To enable grabbing upon a trigger, use the MIL-Lite function `MdigControl()` with `M_GRAB_TRIGGER_STATE`. To set the signal used to trigger the grab, use `MdigControl()` with `M_GRAB_TRIGGER_SOURCE`. To start a timer upon a trigger, use `MdigControl()` with `M_TIMER_TRIGGER_SOURCE`.

## Rotary decoder

Matrox Radiant eV-CXP features four rotary decoders (quadrature decoders). They are used to decode quadrature input received from a rotary encoder with quadrature output. A rotary encoder is a device that provides information about the position and direction of a rotating shaft (for example, that of a conveyor belt). The encoder outputs a two-bit code (also known as Gray code) on two pairs of LVDS wires for each change in position of the rotating shaft; for a given direction of the rotating shaft, the rotary encoder outputs the code in a precise sequence (either 00 - 01 - 11 - 10 or 00 - 10 - 11 - 01, depending on how the rotary encoder is attached to the rotating shaft). If the rotating shaft changes direction, the rotary encoder transmits the Gray code in the reverse sequence (00 - 10 - 11 - 01 or 00 - 01 - 11 - 10, respectively).

Upon decoding a Gray code, the rotary decoder increments or decrements its 32-bit internal counter, depending on the direction of movement. You can configure which Gray code sequence represents forward movement and increments the counter; the reverse Gray code sequence will then represent the backward direction and decrement the counter. You can specify the direction of movement occurring when the Gray code sequence is 00 - 01 - 11 - 10, using `MdigControl()` with `M_ROTARY_ENCODER_DIRECTION`.

The rotary decoder supports encoder frequencies of up to 50MHz. The LVDS receivers of the Matrox Radiant eV-CXP board support input from -4 V to +5 V.

- ❖ Note that an external source must be used to power the rotary encoder (for example, your computer's 5 V power source).

You can configure the rotary decoder's settings, using the MIL-Lite function `MdigControl()` with `M_ROTARY_ENCODER...`, or by modifying the DCF file with Matrox Intellicam.

### User signals

Auxiliary signals can also be used to transmit or receive application-specific user output and/or input.

If you want to start or stop an external event based on some calculation or analysis, you can manually set the state of any auxiliary output signal (or I/O signal set to output) to high or low. To do so, you set the state (on/off) of a bit in a user settable register (static-user-output register). When the bit is on, its associated auxiliary output signal will be high; when it is off, the auxiliary output signal will be low. This bit is referred to as a user-bit. To route the state of a user-bit to an auxiliary output signal, use `MdigControl()` with `M_IO_SOURCE` and `M_USER_BITn`; to set the state of a user-bit, use `MdigControl()` with `M_USER_BIT_STATE`.

Your application can also act upon and interpret the state of an auxiliary input signal (or I/O signal set to input). The state of an auxiliary input signal is not associated with a user-bit; you poll the state of the signal directly. To poll the state of an auxiliary input signal, use `MdigInquire()` with `M_IO_STATUS`. The state of an auxiliary input signal can also generate an interrupt; to do so, use `MdigControl()` with `M_IO_INTERRUPT_STATE` and then use `MdigHookFunction()` with `M_IO_CHANGE` to hook a function to this event (that is, to set up an event handler).

## Acquisition memory

---

Matrox Radient eV-CXP has 1, 2, or 4 Gbytes of DDR3 SDRAM acquisition memory. This memory is accessed through the memory interface, and is used to store acquired images. The memory interface transfers data to and from memory at up to 8.5 Gbytes/sec.

Matrox Radient eV-CXP has 128 Mbytes of memory mapped onto the PCIe bus. You can use a Host pointer to access this memory, or you can access it directly from another PCIe bus master; this memory is referred to as shared memory. To allocate a buffer in shared memory, use the MIL-Lite function `MbufAlloc...()` with `M_ON_BOARD + M_SHARED`.

## Data conversion

---

The color space converter and image formatter can convert data in the following ways:

- **Subsampling.** Image data can be subsampled.

The color space converter and image formatter can subsample in the horizontal and vertical directions by integer factors of 1 to 16. The color space converter and image formatter uses nearest-neighbor interpolation.

You can use any of the following MIL-Lite functions to subsample image data:

- **MdigControl()** with **M\_GRAB\_SCALE\_X/Y**, using a factor of less than 1.
- **MimResize()** with **ScaleFactorX** and **ScaleFactorY** set to a value less than 1.
- **MbufTransfer()** with **M\_COPY + M\_SCALE**, setting the destination buffer size smaller than the original image.

Note that Matrox Radient eV-CXP does not support cropping in hardware. However, you can have image data cropped during transfer to Host using **MdigControl()** with **M\_SOURCE\_SIZE\_X/Y** and **M\_SOURCE\_OFFSET\_X/Y**.

- **Flipping.** Images can be flipped horizontally or vertically, using the MIL-Lite function **MdigControl()** with **M\_GRAB\_DIRECTION\_X/Y** or when calling **MimFlip()** from on-board buffer to Host.
- **Color space conversion.** The color space converter and image formatter formats an image based on its type and the bit-depth and color format of the destination buffer. You can set the bit depth and color format of the destination buffer when you allocate it using the MIL-Lite function **MbufAlloc...()**. The format of the source image is established in the DCF.

Image data can be converted as follows:

Input format	Output format							
	8-bit monochrome	16-bit monochrome	24-bit packed BGR	32-bit packed BGRa	48-bit packed BGR	16-bit YUV (YUYV)	24-bit RGB planar	48-bit RGB planar
8-bit monochrome	yes		yes	yes		yes	yes	
16-bit monochrome	yes	yes	yes	yes	yes	yes	yes	yes
24-bit packed BGR	yes		yes	yes		yes	yes	
48-bit packed BGR	yes	yes	yes	yes	yes	yes	yes	yes

The equations for the YUV16 conversion are described in the following table. The value of *depth* is either 8 or 16 when converting BGR24 or BGR48 data, respectively. Note that while performing BGR48-to-YUV color space conversion, the operations are carried out on 16-bit data; then each resulting YUV component is bit-shifted right by 8 bits ( $\gg (\text{depth} - 8)$  where the value of *depth* is 16).

Color space conversion	Equations
BGR-to-YUV	<ul style="list-style-type: none"> <li><math>Y = (0.114B + 0.587G + 0.299R) \gg (\text{depth} - 8)</math></li> <li><math>U = (0.500B - 0.331G - 0.169R + 2^{(\text{depth}-1)}) \gg (\text{depth} - 8)</math></li> <li><math>V = (-0.081B - 0.419G + 0.500R + 2^{(\text{depth}-1)}) \gg (\text{depth} - 8)</math></li> </ul>

## Host interface

---

The Matrox Radiant eV-CXP PCIe 2.0 Host interface is capable of high-speed DMA transfers to Host memory, or other memory mapped onto the PCIe bus. The DMA write engine of the Host interface is capable of performing the transfers without the help of the Host CPU.

Matrox Radiant eV-CXP uses PCIe 2.0 technology to communicate with the Host. Under optimum conditions, Matrox Radiant eV-CXP can send data to the Host at a peak transfer rate of up to 4 Gbytes/sec. Optimum conditions include using the board in a PCIe 2.x slot with 8 active lanes, using a 256-byte payload.

DMA write performance is chipset and computer dependent, and is slightly affected by the image size and alignment in Host memory.

The Matrox Radiant eV-CXP Host interface has four DMA write contexts, which act independently, simulating four DMA write engines running in parallel. The presence of multiple DMA contexts does not change the maximum bandwidth, but can help reduce latency.



# **Appendix A:**

# **Glossary**

This appendix defines some of the specialized terms used in the Matrox Radient eV-CXP documentation.

## **Glossary**

---

- **Acquisition path.**

A path that has the components to, for example, digitize or capture a video input signal.

- **ASPM.**

*Active State Power Management.* A hardware PCIe mechanism that autonomously controls power consumption of the PCIe connectors in a computer. The actual power consumed by a PCIe device depends on the PCIe traffic and on the power-saving level to which the PCIe slot is configured. The power-saving level of the PCIe slot is initialized by the operating system.

- **Auxiliary I/O.**

*Auxiliary input/output.* Non-video signals that can support one or more functionalities depending on the auxiliary signal (for example, trigger input or timer output).

- **Bandwidth.**

A term describing the capacity to transfer data. Greater bandwidth is needed to sustain a higher transfer rate. Greater bandwidth can be achieved, for example, by using a wider bus or by increasing the clock frequency at which an interface or a processing core operates (for example, increasing the DDR3 SDRAM clock frequency).

- **BNC connector.**

*Bayonet Neill-Concelman connector.* A common connector used for 75  $\Omega$  coaxial cables. Its fastener uses L-shaped slots to ensure that the coaxial cable is secured to the Matrox Radiant eV-CXP board.

- **CoaXPress.**

An asymmetric high-speed communication standard used primarily for video and image data transfer. CoaXPress supports the transmission of video data, control signals, triggers, and power all on the same coaxial line. For each connection, CoaXPress supports downlink data rates of up to 6.25 Gbits/sec (1.25, 2.5, 3.125, 5.0, and 6.25 Gbits/s) and an uplink data rate of 0.02 Gbits/s (20.83 Mbits/sec).

- **Contiguous memory.**

A block of memory occupying a single, unbroken series of addresses.

- **CXP.**

See *CoaXPress*.

- **DCF.**

*Digitizer configuration format.* A format that defines how the video source and the frame grabber are configured. The video source and the frame grabber are set to the specified camera mode, which defines the format of transferred data. The DCF can also configure the triggers, timers, and rotary decoders.

DCF files have a *.dcf* extension.

- **DDR3 SDRAM.**

*Double-data-rate type 3 synchronous dynamic random-access memory.* A type of general purpose consumer RAM. DDR3 SDRAM allows for data transfer at very high speeds, which is important for I/O-bound functions. This type of memory is inexpensive, high density, and very efficient as long as the data is accessed contiguously.

- **Digitizer configuration format.**

See *DCF*.

- **Dynamic range.**

The range of values present in a buffer. An unsigned 8-bit buffer, for example, has an allowable range of 0 to 255; its dynamic range can be any range within these values.

- **Exposure time.**

Refers to the period during which the image sensor of a video source is exposed to light. As the length of this period increases, so does the image brightness.

- **Frame.**

A single image grabbed from a video source.

- **Grab.**

To acquire an image from a video source.

- **Latency.**

The time from when a command is sent to when its operation is started.

- **LVDS.**

*Low-voltage differential signaling.* LVDS offers a general-purpose, high bandwidth interface standard for serial and parallel data interfaces that require increased bandwidth at high speed, with low noise and power consumption.

- **PCIe.**

*Peripheral Component Interconnect Express.* The standard used for the computer bus that acts as an interface between hardware devices, such as Matrox Radiant eV-CXP, and your computer.

- **Payload.**

The amount of data transmitted to the PCIe bus within each data packet. Common payload sizes are 128, 256, 512, 1024, 2048, and 4096 bytes.

- **PoCXP.**

*Power-over-CoaXPress.* Power-over-CoaXPress is the term for power transmitted to a video source over a coaxial cable using the CoaXPress standard. Power can be provided to a video source, at up to 13 W per cable, at a nominal voltage of 24 V.

- **Real-time processing.**

The processing of an image at the same speed or faster than the speed at which images are grabbed. Real-time processing ensures that no frames are missed.

Also known as *live processing*.

- **Rotary encoder.**

A device used to convert the angular position of a shaft or axle to an analog or digital code.

- **Timer output.**

The signal generated by one of the programmable timers of the frame grabber. The timer output can be used to control external hardware. For example, it can be fed to the video source to control its exposure time or can be used to fire a strobe light.



# **Appendix B: Technical information**

This appendix contains information that might be useful when installing your Matrox Radiant eV-CXP board.

## **Board summary**

---

### **Global information**

- Operating system: See your software manual for supported versions of Microsoft Windows and Linux.
- Minimum computer requirements:
  - x8 (or x16) PCIe 1.x or 2.x slot<sup>\*</sup>.
  - Processor with an Intel 32-bit or 64-bit architecture, or equivalent.
  - A relatively up-to-date PCIe chipset. A chipset that supports the PCIe 2.x standard is preferable. The list of platforms that are known to be compatible with Matrox Radiant eV-CXP is available on the Matrox website, under the board's PC compatibility list.
  - A proper power supply. Refer to the *Electrical specifications* section.

Matrox does not guarantee compatibility with all computers that have the above specifications. Please consult with your local Matrox Imaging representative, local Matrox Imaging sales office, the Matrox web site, or the Matrox Imaging Customer Support Group at headquarters before using a specific computer.

---

\*. Note that you can also install Matrox Radiant eV-CXP in a x4 PCIe slot that has a mechanical x8 connector; however, the maximum transfer rate between Matrox Radiant eV-CXP and the Host is reduced by 50%.

**Technical features of Matrox Radiant eV-CXP**

- Supports four independent CoaXPress connections (using the board's four independent acquisition paths). Image data can be transmitted at up to 6.25 Gbits/sec when using a single coaxial cable (1.25, 2.5, 3.125, 5.0, or 6.25 Gbits/s), and up to 25 Gbits/sec when using four cables.
- Provides power-over-CoaXPress (PoCXP) (up to 13 W per connection) to any PoCXP-compliant device. The board is equipped with an overcurrent protection mechanism and a resettable fuse. The fuse can sustain a current of 1 A.
- Has a x8 PCIe 2.0 Host interface.
- Supports coaxial cable lengths of up to 40 m running at 6.25 Gbits/sec.
- Supports frame and line-scan video sources. The minimum and maximum number of pixels per line are 33 and 65535, respectively.
- Supports video sources with a Bayer color filter. Bayer-encoded data (GRBG, GBRG, BGGR, or RGGB) is converted to RGB.
- Can convert 8- or 16-bit monochrome or 24- or 48-bit packed BGR data to monochrome, packed or planar BGR, packed BGRa, or YUV (YUYV) format.
- Can perform horizontal or vertical flipping.
- Can subsample image data by integer subsampling factors of 1 to 16.
- Has 1, 2, or 4 Gbytes of DDR3 SDRAM. Total memory bandwidth of up to 8.5 Gbytes/sec.
- Supports external 5 V rotary encoders with quadrature output.

## 54 **Appendix B: Technical information**

- Has up to 32 auxiliary signals (with the cable adapter brackets installed) that are path independent. Each auxiliary I/O connector provides the following number of signals:
  - Three TTL auxiliary I/O signals (trigger input or user input signals, or timer output, re-routing of the CoaXPress trigger input, or user output signals).
  - One LVDS auxiliary output signal (timer output, re-routing of the CoaXPress trigger input, or user output signals).
  - Two LVDS auxiliary input signals (trigger input, quadrature input, or user input signals).
  - Two opto-isolated auxiliary input signals (trigger input signals).
- The auxiliary input signals (or auxiliary I/O signals set to input) can be re-routed onto the CoaXPress trigger output signal.
- Has four CoaXPress LEDs, one for each CoaXPress input connector, to identify the status and activity of connected devices.
- Has four board status LEDs to indicate the status of each of the following: power, board configuration, PCIe (Host) slot, and firmware.

## Electrical specifications

Matrox Radient eV-CXP (starting from version 000)	
Operating voltage and current (eV-CXP)	<p>Typical: 3.3 V, 425 mA: 1.4 W            Typical 12.0 V, 1.2 A: 14.4 W</p> <p>Max. PoCXP 18.5 - 24.0 V, 700 mA: 17 W* (Current drawn from the PCIe auxiliary power connector. Power is not dissipated by the board; it is only used by the video source).</p> <p>Total dissipated by the board: 1.4 W + 14.4 W = 15.8 W (typical)</p> <p>Total dissipated by board and PoCXP video sources = 15.8 W + (4 * 17 W) = 83.8 W (typical)</p>
I/O Specifications	
Input signals in LVDS format	<p>100 Ohm differential termination.</p> <p>Input current: -10 <math>\mu</math>A (min) to +10 <math>\mu</math>A (max).</p> <p>Common-mode: -4 V (min) to +5 V (max).</p> <p>Differential threshold: low of -50 mV (min); high of +50 mV (max).</p>
Output signals in LVDS format	<p>No parallel termination.</p> <p>Output current: -10 <math>\mu</math>A to 10 <math>\mu</math>A.</p> <p>Output voltage: high (<math>V_{oh}</math>) 1.6 V (max), 1.33 V (typ); low (<math>V_{ol}</math>) 0.9 V (min), 1.02 V (typ)</p> <p>Differential output voltage (with load of 100 Ohm): 250 mV (min) to 450 mV (max).</p> <p>Offset voltage (common-mode): 1.125 V (min) to 1.375 V (max).</p> <p>Propagation delay: 2.8 ns (max).</p>
Input signals in TTL format	<p>No series termination.</p> <p>Pulled up to 3.3 V with 4.716 K Ohm.</p> <p>Clamped to -0.7 V to +5.7 V.</p> <p>Input current: 5 <math>\mu</math>A (max).</p> <p>Input voltage: low of 0.8 V (max); high of 2.0 V (min).</p>
Output signals in TTL format	<p>27 Ohm series termination.</p> <p>High-level output current: -32 mA (max).</p> <p>Low-level output current: +64 mA (max).</p> <p>Output voltage: low of 0.55 V (max); high of 2.0 V (min).</p>
Opto-coupled input signals <sup>†</sup>	<p>511 Ohm series termination (connected on the anode inputs of the opto-coupler device).</p> <p>Input current: low: 250 <math>\mu</math>A (max); high: 5 mA (min (thresholded)) to 15 mA (max) (6.3 to 10 mA recommended).</p> <p>Input voltage: low (<math>V_{il}</math>) of 0.8 V (max); high (<math>V_{ih}</math>) of 4.71 V (min) to 9.165 V (max).</p> <p>Input forward voltage (at 25 degrees C): 1.3 V (min), 1.8 V (max).</p> <p>Propagation delay (at 25 degrees C): 100 ns (max).</p>

\*. The PoCXP protection fuse on Matrox Radient eV-CXP can sustain a current of 1 A.

†. The Matrox Radient eV-CXP opto-couplers are manufactured by Agilent or Avago Technologies (P/N HCPL-0631).

## **Dimensions and environmental specifications**

---

- Dimensions of Matrox Radiant eV-CXP: 16.76 L x 11.12 H x 1.871 W cm (6.6" x 4.376" x 0.737") from bottom edge of goldfinger to top edge of board. These values respect the dimensions of a PCIe half-length board.
- Ventilation: 200 LFM between boards.
- Minimum/maximum ambient operating temperature: 0°C to 55°C (32°F to 131°F).
- Minimum/maximum storage temperature: -40°C to 75°C (-40°F to 167°F).
- Operating relative humidity: up to 95% relative humidity (non-condensing).
- Storage humidity: up to 95% relative humidity (non-condensing).

## Connectors on the Matrox Radiant eV-CXP board

On the Matrox Radiant eV-CXP board, there are several interface connectors. On the bracket of the main board, there are four CoaXPress video input connectors and one Mini DisplayPort (MiniDP) connector. In addition, close to the top edge of the main board, there are two internal auxiliary I/O connectors and a 12 V PCIe auxiliary power connector.

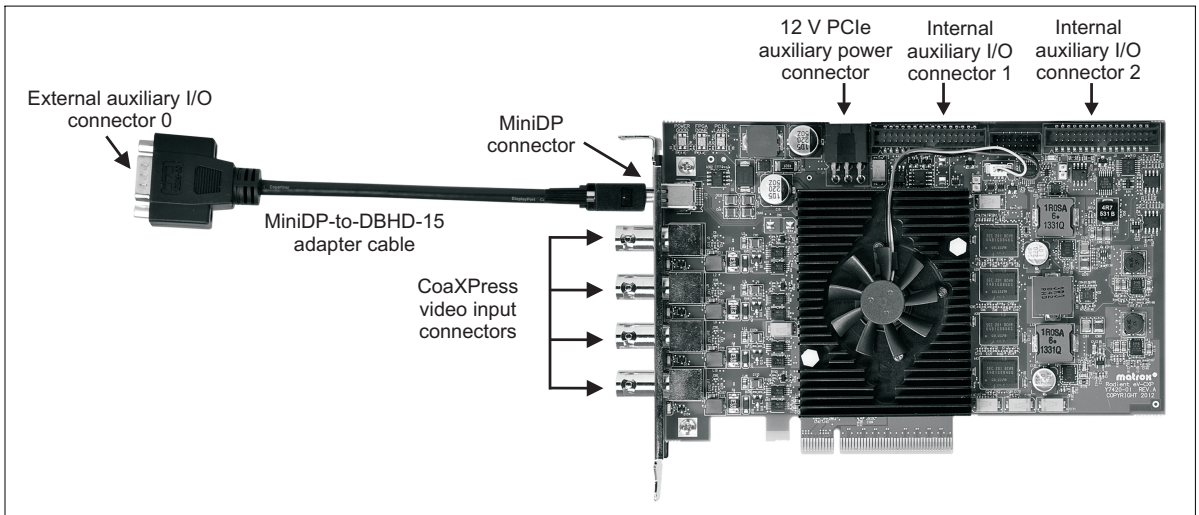

The MiniDP-to-DBHD-15 adapter cable connects to the MiniDP connector on the main bracket. The DBHD-15 connector at the end of this cable is called external auxiliary I/O connector 0.

The optional cable adapter brackets provide three additional external auxiliary I/O connectors. The primary cable adapter bracket (the bracket attached to internal auxiliary I/O connector 1) has auxiliary I/O connectors 1 and 2. The secondary cable adapter bracket (the bracket attached to internal auxiliary I/O connector 2) has auxiliary I/O connector 3 and an unused connector.

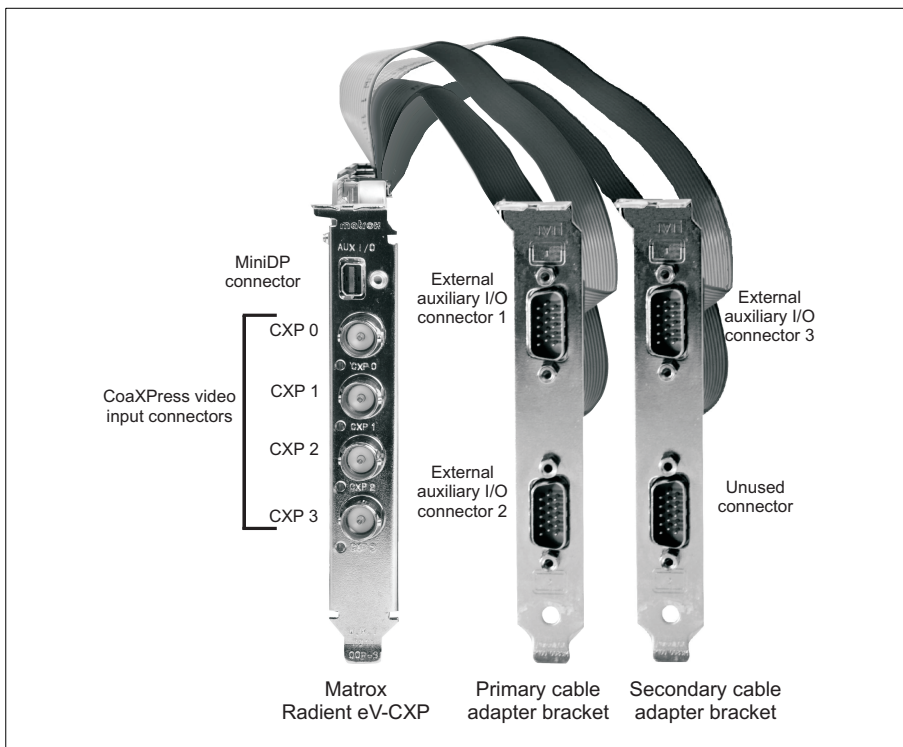

### **CoaXPress video input connectors**

The four CoaXPress (CXP) video input connectors are standard 75  $\Omega$  BNC connectors. They are used to receive video input streams and send and receive CoaXPress trigger signals, as well as control and acknowledgement messages.

To interface with these connectors, use standard 75  $\Omega$  coaxial cables with BNC connectors. You can purchase high-quality, 75  $\Omega$  coaxial cables from your video source manufacturer, Belden Inc., or other third parties. Note that these cables are not available from Matrox.

When using more than one CoaXPress cable to connect to the same video source, you must choose cables of the same type and length, to ensure that the cables have the same propagation delay.

Video sources can be connected to the CoaXPress video input connectors in any order. Matrox Radiant eV-CXP communicates with the video source(s) to identify which video source is connected to which connector(s).

### External auxiliary I/O connectors

The external auxiliary I/O connectors on the MiniDP-to-DBHD-15 adapter cable and the cable adapter brackets are high-density D-subminiature 15-pin (DBHD-15\*) male connectors. The external auxiliary I/O connectors are used to transmit and receive auxiliary signals.

- ❖ The auxiliary I/O connectors on Matrox Radiant eV-CXP are not compatible with display devices. Connecting one of the DBHD-15 connectors to a VGA monitor or any other display device might damage both the device and the Matrox Radiant eV-CXP board.

The auxiliary signals are path independent; regardless of the acquisition path that is being used to grab images, any of the auxiliary signals can be used. For more information, see the *Auxiliary signals* section in *Chapter 4: Matrox Radiant eV-CXP hardware reference* chapter for supported functionality.

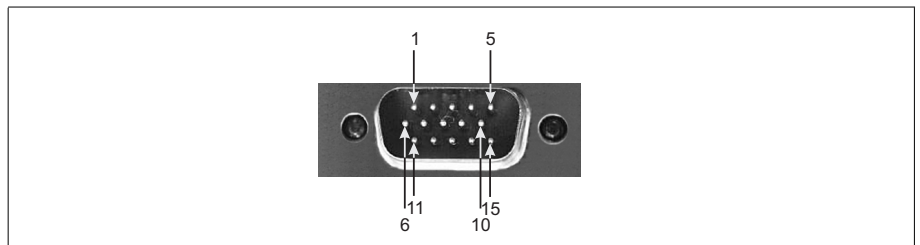

---

\*. Sometimes referred to as DB-15, but more accurately known as DE-15.

The pinout for auxiliary I/O connector 0 is as follows. Auxiliary I/O connectors 1, 2, and 3 have the same pinout as auxiliary I/O connector 0, except you must add 8, 16, or 24, respectively, to the number at the end of their hardware signal name and MIL constant. For example, AUX(TRIG)\_TTL\_IO\_4 on connector 0 would be AUX(TRIG)\_TTL\_IO\_12 on connector 1.

Pin	Hardware signal name	MIL constant for auxiliary signal	Description
1	AUX(TRIG)_TTL_IO_4	M_AUX_I04	TTL auxiliary signal 4 (input/output), which supports: timer output (M_TIMER1/M_TIMER2/M_TIMER3/M_TIMER4), trigger input, user input, or user output (M_USER_BIT4).
2	AUX(TRIG)_TTL_IO_5	M_AUX_I05	TTL auxiliary signal 5 (input/output), which supports: timer output (M_TIMER1/M_TIMER2/M_TIMER3/M_TIMER4), trigger input, user input, or user output (M_USER_BIT5).
3	AUX(TRIG)_TTL_IO_6	M_AUX_I06	TTL auxiliary signal 6 (input/output), which supports: timer output (M_TIMER1/M_TIMER2/M_TIMER3/M_TIMER4), trigger input, user input, or user output (M_USER_BIT6).
4+, 5-	AUX(TRIG)_LVDS_IN2	M_AUX_I02	LVDS auxiliary signal 2 (input), which supports: trigger input, user input, or quadrature input bit 0.
6+, 8-	AUX(TRIG)_LVDS_IN3	M_AUX_I03	LVDS auxiliary signal 3 (input), which supports: trigger input, user input, or quadrature input bit 1.
7	GND	N/A	Ground.
10	GND	N/A	Ground.
12+, 11-	AUX(TRIG)_OPTO_IN1	M_AUX_I01	Opto-isolated auxiliary signal 1 (input), which supports: trigger input or user input.
13+, 14-	AUX(EXP)_LVDS_OUT7	M_AUX_I07	LVDS auxiliary signal 7 (output), which supports: timer output (M_TIMER1/M_TIMER2/M_TIMER3/M_TIMER4) or user output (M_USER_BIT7).
15+, 9-	AUX(TRIG)_OPTO_IN0	M_AUX_I00	Opto-isolated auxiliary signal 0 (input), which supports: trigger input or user input.

To build your own cable, you can purchase the following parts:

	Mating information
Manufacturer:	NorComp, Inc.
Connector:	180-015-203L001
Backshell:	970-015-010-011

These parts can be purchased from third parties such as Digi-Key Corporation ([www.digikey.com](http://www.digikey.com)).

### PCIe auxiliary power connector

The PCIe auxiliary power connector on Matrox Radiant eV-CXP is a standard 6-pin, 12 V connector. When this connector is connected to the 12 V power supply of your computer, Matrox Radiant eV-CXP can provide power-over-CoaXPress to the devices connected to the CoaXPress input connectors, at up to 13 W per connection.

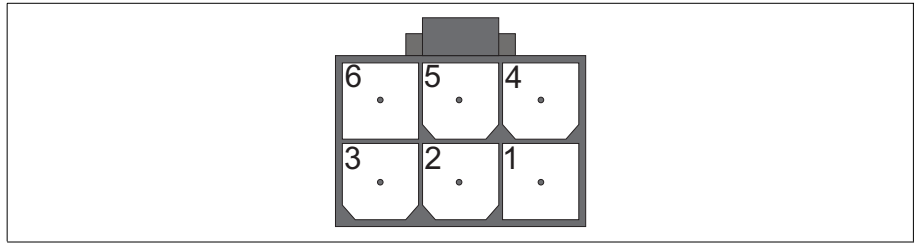

The pinout for the PCIe auxiliary power connector is as follows:

Pin	Description
1	+ 12 V
2	+ 12 V
3	+ 12 V
4	Ground
5	Sense
6	Ground

## LEDs on Matrox Radiant eV-CXP

---

Matrox Radiant eV-CXP has LEDs to display the status of the CoaXPress connections, the on-board power, the board configuration, the PCIe (Host) slot, and the firmware.

### CoaXPress LEDs

Matrox Radiant eV-CXP has four CoaXPress LEDs on the main bracket. Each LED corresponds to a CoaXPress video input connector, indicates the status of the device attached to that connector, and indicates communication between the device and Matrox Radiant eV-CXP. The LED can help identify whether the device is sending data, and whether Matrox Radiant eV-CXP is transmitting power to the device.

LED color and state	Description
Off	Matrox Radiant eV-CXP is not receiving power.
Red, slow flash	Matrox Radiant eV-CXP is sensing for a PoCXP-compliant device.
Red, 500 ms flash	An error occurred during data transfer.
Red, fast flash	A CoaXPress system error occurred on the Matrox Radiant eV-CXP board. This type of error can prevent Matrox Radiant eV-CXP from receiving data. For example, an error will occur if PoCXP is enabled, but the auxiliary 12 V power connector is not connected to a power source.
Red, solid	Overcurrent was detected in the PoCXP circuitry, possibly because of a failure in the connected device or damage to the cable. Matrox Radiant eV-CXP stopped sending power to the device to avoid damaging the device or the board.
Alternating red/orange, slow flash	One of the following is occurring: <ul style="list-style-type: none"> <li>• Matrox Radiant eV-CXP is sensing for a non-PoCXP compliant device. PoCXP is disabled.</li> <li>• The device is incompatible. PoCXP is disabled.</li> </ul>
Alternating red/green, slow flash	The device is incompatible; PoCXP is enabled.
Orange, slow flash	Matrox Radiant eV-CXP is waiting for an event (for example, a trigger).
Green, slow flash	The device is compatible and Matrox Radiant eV-CXP has established a connection with the device. No data is being transferred.
Orange, fast flash	Matrox Radiant eV-CXP detected a non-PoCXP compliant device. Matrox Radiant eV-CXP is trying to establish a connection with the device, without sending power to the device. This state occurs when initially connecting your device.
Green, fast flash	Matrox Radiant eV-CXP detected a PoCXP-compliant device. Matrox Radiant eV-CXP is sending power to the device, and is trying to establish a connection. This state occurs when initially connecting your device.
Green, solid	Matrox Radiant eV-CXP has established a connection with the device and data is being transferred. The LED blinks synchronously with data.
Orange, solid	Matrox Radiant eV-CXP is booting, or the PoCXP circuitry is not ready.

## Board status LEDs

Matrox Radiant eV-CXP has four board status LEDs to indicate the status of each of the following: power, the board configuration, the PCIe (Host) slot, and the firmware.

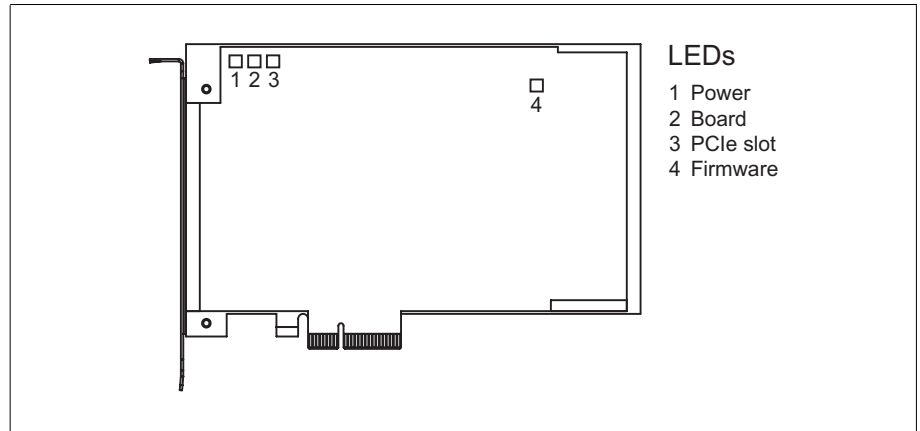

The table below outlines the possible colors for each LED, and their definitions.

LED type	LED color and state	Description
1. Power	Off/Red	One or more of the on-board voltage regulators did not start. If your computer is on and this LED state occurs, there is an issue with the voltage regulators on your Matrox Radiant eV-CXP. Please contact Matrox technical support.
	Green	All of the on-board voltage regulators are working properly.
2. Board	Red	The board is not configured.
	Green	The board is configured.
3. PCIe slot	Off	The type of slot cannot be established. The PCIe link is down.
	Blinking red	Slot is PCIe 1.x, x1
	Blinking orange	Slot is PCIe 1.x, x4
	Blinking green	Slot is PCIe 1.x, x8
	Solid red	Slot is PCIe 2.x, x1
	Solid orange	Slot is PCIe 2.x, x4
4. Firmware status	Off	The firmware is OK.
	On	The firmware is corrupted. Fall-back firmware is being used.



# **Appendix C: Listing of Matrox Radiant eV-CXP boards**

This appendix lists the key feature changes to the Matrox Radiant eV-CXP board.

## **Key feature changes**

---

<b>Part number</b>	<b>Version</b>	<b>Description</b>
RAD EV 1G 4C6*	000	First shipping version.
	001	Moved CoaXPress connectors. Replaced DBHD-15 connector on main bracket with a Mini DisplayPort (MiniDP) connector. Product ships with MiniDP-to-DBHD-15 adapter cable.

# Index

## A

acquisition features 32, 34  
acquisition memory 40  
acquisition path 30  
ASPM 21  
    defined 46  
auxiliary signals 10, 36–37, 40, 54, 59–60

## B

bandwidth 28, 34  
    defined 46  
BNC connector 46, 58

## C

cable adapter bracket 20, 22, 24  
CoaXPress 8–9, 20, 25, 32, 35, 47, 59  
    connecting cables 25, 59  
CoaXPress interface 34  
color space conversion 41–42  
computer requirements 12  
connectors  
    CoaXPress with BNC connectors 23, 25, 58  
    external auxiliary I/O connector 23, 59–60  
    MiniDP connector 23, 57

## D

data transfer 8, 10, 34, 41  
DBHD-15 connector 14  
DCF  
    defined 47  
    see digitizer configuration format  
DDR3 SDRAM 40  
    defined 47  
digitizer configuration format 30  
digitizer, MIL 30  
dynamic range  
    defined 48

## E

electrical specifications 55  
external auxiliary I/O connector 59–60

## F

flip 41  
frame  
    defined 48

## G

global information 52–53

## H

hardware 30  
Host interface 43

## I

independent acquisition path 30  
installation  
    hardware 18  
    multiple boards 28  
    overview 15

## K

Key feature changes to Matrox Radiant eV-CXP 66

## L

LEDs 26, 62–63  
LUTs 35  
LVDS  
    defined 48

## M

Matrox Intellicam 12, 30  
Matrox Radiant eV-CXP 8, 32, 55, 57  
MIL 10, 14–15  
MIL-Lite 11, 14, 28, 34–35, 37–41  
MiniDP connector 23, 57  
MiniDP-to-DBHD-15 adapter cable 13, 23, 57  
monochrome 32  
multiple boards 28

## N

non-PoCXP 34

## **P**

- PCIe 12
  - 2.x 10, 12, 18, 28, 34, 43
  - defined 48
- PCIe slot 12, 18–19, 34
- PoCXP 26, 34, 55
  - defined 49
- power 21, 34, 55

## **Q**

- Quadrature input
  - Gray code 39

## **R**

- requirements
  - computer 12
- RGB 9, 32
- rotary decoders 39

## **S**

- SDRAM 9, 40, 53
  - defined 47
- software supported 10
- specifications
  - electrical 55
  - technical 52–53

## **T**

- technical specifications 52–53
- timer output 38
  - defined 49
- triggers 38

## **U**

- user signals 40

## **V**

- video sources supported
  - monochrome 32
  - RGB 9, 32

# Regulatory Compliance

## FCC Compliance Statement

### Warning

Changes or modifications to these units not expressly approved by the party responsible for the compliance could void the user's authority to operate this equipment.

The use of shielded cables for connections of these devices to other peripherals is required to meet the regulatory requirements.

### Note

These devices comply with Part 15 of FCC Rules. Operation is subject to the following two conditions:

1. These devices may not cause harmful interference, and
2. These devices must accept any interference received, including interference that may cause undesired operation.

This equipment has been tested and found to comply with the limits for Class A digital devices, pursuant to Part 15 of the FCC Rules. These limits are designed to provide reasonable protection against harmful interference when the equipment is operated in a commercial environment. This equipment generates, uses, and can radiate radio frequency energy and, if not installed and used in accordance with the instruction manual, may cause harmful interference to radio communications. Operation of these devices in a residential area is likely to cause harmful interference in which case the user will be required to correct the interference at his/her own expense.

## Industry Canada Compliance Statement

These digital apparatuses do not exceed the Class A limits for radio noise emission from digital apparatuses set out in the Radio Interference Regulations of Industry Canada.

Ces appareils numériques n'émettent pas de bruits radioélectriques dépassant les limites applicables aux appareils numériques de Classe A prescrites dans le Règlement sur le brouillage radioélectrique édicté par Industrie Canada.

## EU Notice (European Union)

**WARNING:** These are class A products. In a domestic environment these products may cause radio interference in which case the user may be required to take adequate measures.

**AVERTISSEMENT:** Ces appareils sont des produits informatiques de Classe A. Lorsque ces appareils sont utilisés dans un environnement résidentiel, ces produits peuvent entraîner des interférences radioélectriques. Dans ce cas, l'utilisateur peut être prié de prendre des mesures correctives appropriées.

This device complies with EC Directive 89/336/EEC for Class A digital devices. They have been tested and found to comply with EN55022/CISPR22 and EN55024/CISPR24 when installed in a typical class A compliant host system. It is assumed that these devices will also achieve compliance in any Class A compliant system.

Ces unités sont conformes à la Directive communautaire 89/336/EEC pour les unités numériques de Classe A. Les tests effectués ont prouvé qu'elles sont conformes aux normes EN55022/CISPR22 et EN55024/CISPR24 lorsqu'elles sont installées dans un système hôte typique de la Classe A. On suppose qu'elles présenteront la même compatibilité dans tout système compatible de la Classe A.

## **Directive on Waste Electrical and Electronic Equipment (WEEE)**

### **Europe**

#### **(English) European user's information – Directive on Waste Electrical and Electronic Equipment (WEEE)**

Please refer to the Matrox Web site ([www.matrox.com/environment/weee](http://www.matrox.com/environment/weee)) for recycling information.

#### **(Français) Informations aux utilisateurs Européens – Règlementation des déchets d'équipements électriques et électroniques (DEEE)**

Se référer au site Web de Matrox ([www.matrox.com/environment/weee](http://www.matrox.com/environment/weee)) pour l'information concernant le recyclage.

#### **(Deutsch) Information für europäische Anwender – Europäische Regelungen zu Elektro- und Elektronikgeräten (WEEE)**

Bitte wenden Sie sich an dem Matrox-Website ([www.matrox.com/environment/weee](http://www.matrox.com/environment/weee)) für Recycling Informationen.

#### **(Italiano) Informazioni per gli utenti europei – Direttiva sui rifiuti di apparecchiature elettriche ed elettroniche (RAEE)**

Si prega di riferirsi al sito Web Matrox ([www.matrox.com/environment/weee](http://www.matrox.com/environment/weee)) per le informazioni di riciclaggio.



# Limited warranty

Refer to the warranty statement that came with your product.

