

Matrox Orion HD

Installation and Hardware Reference

Manual no. Y11184-101-0200

February 7, 2014

Matrox® is a registered trademark of Matrox Electronic Systems Ltd.

Microsoft® and Windows®, are registered trademarks of Microsoft Corporation.

PCI-X® and PCI Express® are registered trademarks of PCI-SIG. In addition, PCIe is a trademark of PCI-SIG.

VNC® is a registered trademark of RealVNC Ltd. in the U.S. and other countries.

All other nationally and internationally recognized trademarks and tradenames are hereby acknowledged.

Patent Notice

This product may be protected by one or more patents. See www.matrox.com/patents.

© Copyright Matrox Electronic Systems Ltd., 2011-2014. All rights reserved.

Limitation of Liabilities: In no event will Matrox or its suppliers be liable for any indirect, special, incidental, economic, cover or consequential damages arising out of the use of or inability to use the product, user documentation or related technical support, including without limitation, damages or costs relating to the loss of profits, business, goodwill, even if advised of the possibility of such damages. In no event will Matrox and its suppliers' liability exceed the amount paid by you, for the product.

Because some jurisdictions do not allow the exclusion or limitation of liability for consequential or incidental damages, the above limitation may not apply to you.

Disclaimer: Matrox Electronic Systems Ltd. reserves the right to make changes in specifications at any time and without notice. The information provided by this document is believed to be accurate and reliable. However, neither Matrox Electronic Systems Ltd. nor its suppliers assume any responsibility for its use; or for any infringements of patents or other rights of third parties resulting from its use. No license is granted under any patents or patent right of Matrox Electronic Systems Ltd.

PRINTED IN CANADA

Contents

Chapter 1: Introduction 5

Matrox Orion HD board	6
General acquisition features	7
Display features	9
Memory	9
Data transfer	10
Limitations of Matrox Orion HD	10
Software	12
Essentials to get started	13
Inspecting the Matrox Orion HD package	14
Standard items	14
Available separately	15
Handling components	15
Installation	16

Chapter 2: Hardware installation 17

Installing your Matrox Orion HD board	18
Connecting external devices	21
Matrox Orion HD bracket interface connectors	21
Connecting SDI digital display devices	22
Connecting DVI-D and RGB display devices	23
Connecting SDI digital video sources	25
Connecting video sources of other supported formats	26

Chapter 3: Using multiple Matrox Orion HD boards 29

Installation of multiple boards	30
---	----

Simultaneous image capture from different boards	30
--	----

Appendix A: Glossary. 31

Glossary	32
--------------------	----

Appendix B: Technical information. 39

Board summary	40
Global information	40
Technical features of Matrox Orion HD	41
Electrical specifications	43
Dimensions and environmental specifications	43
Connectors on Matrox Orion HD boards	44
SDI video output connectors	45
SDI video input connectors	46
Multi-format input/output connector and the Matrox KX20 to 4 DVI-I cable adapter	47

Appendix C: Major revisions of Matrox Orion HD boards 51

Major revisions of Matrox Orion HD	52
--	----

Index

Regulatory Compliance

FCC Compliance Statement

Industry Canada Compliance Statement

EU Notice (European Union)

Directive on Waste Electrical and Electronic Equipment (WEEE)

Limited Warranty

Chapter

1

Introduction

This chapter briefly describes the features of the Matrox Orion HD board, as well as the software that can be used with the board.

Matrox Orion HD board

Matrox Orion HD is a high-performance graphics adapter (display board) with video capture capabilities. Both in display and acquisition, the board supports standard definition (SD) and high-definition (HD) analog or digital video.

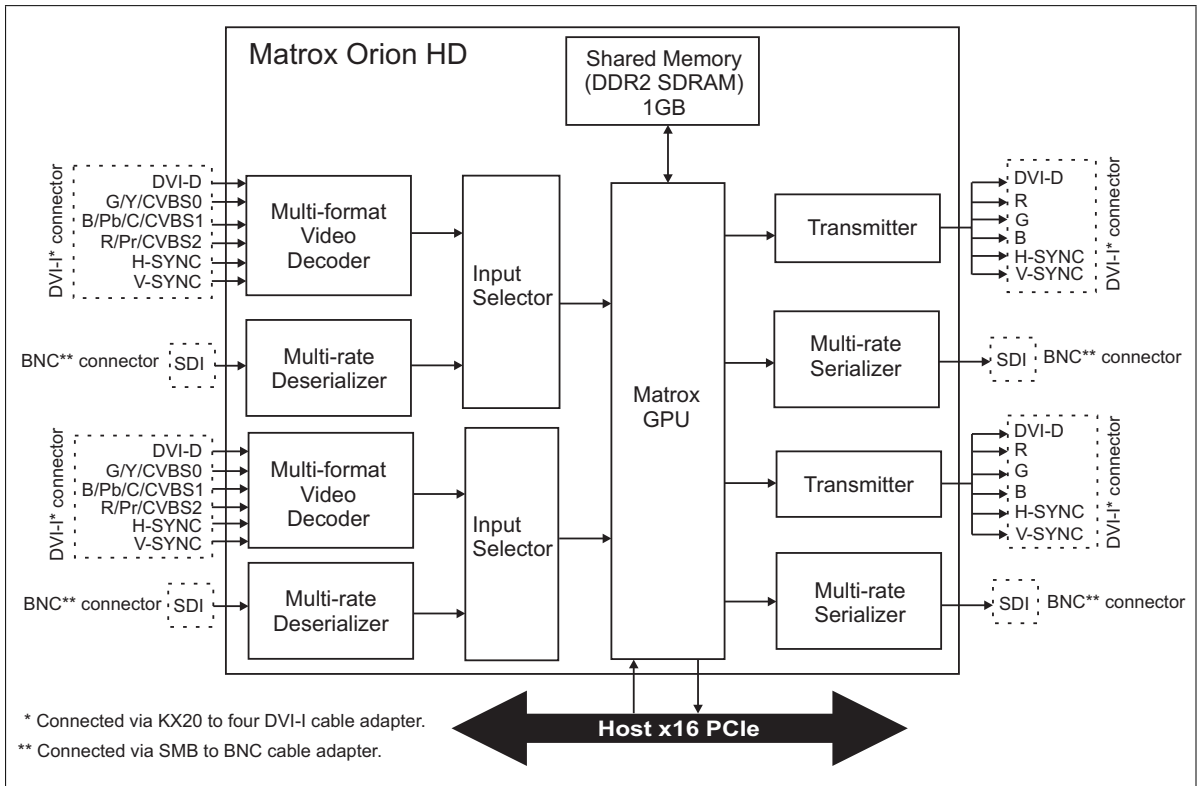

General acquisition features

Matrox Orion HD has four acquisition paths, but can grab only from any two independently at any one time. Two of the acquisition paths support SD or HD 3G-SDI digital video input using a multi-rate deserializer. The other two acquisition paths support multiple video input formats using a multi-format video decoder; they support RGB (including DVI-A), YPbPr, Y/C, or CVBS analog video input or DVI-D digital video input. The table below summarizes the supported acquisition video formats:

Acquisition video formats					
Type	Transmission standard	Standard resolution	Digital video		Analog video (using multi-format video decoder only)
			Using multi-rate deserializer	Using multi-format video decoder	
Standard Definition (SD)	576i at 25 frames/sec (PAL)	720 x 576 (non-square pixels)	SD-3G-SDI	-	CVBS, RGB, Y/C, YPbPr (non-square pixels)
	486i at 30 frames/sec (NTSC)	720 x 486 (non-square pixels)	SD-3G-SDI	-	CVBS, RGB, Y/C, YPbPr (non-square pixels)
High Definition (HD)	720p at 60 frames/sec	1280 x 720	HD-3G-SDI	DVI-D	RGB
	1080i at 60 frames/sec	1920 x 1080	HD-3G-SDI	DVI-D	RGB
	1080p at 60 frames/sec	1920 x 1080	HD-3G-SDI	DVI-D	RGB

The two acquisition paths that support multiple video input formats also support video input from display boards (graphics adapters) in standard resolutions. The table below summarizes the supported standard resolutions:

Standard resolution	Digital video	Analog video	Maximum refresh rate
1920 × 1200	DVI-D	RGB	60 Hz
1920 × 1080	DVI-D	RGB	60 Hz
1600 × 1200	DVI-D	RGB	60 Hz
1280 × 1024	DVI-D	RGB	85 Hz
1024 × 768	DVI-D	RGB	85 Hz
800 × 600	DVI-D	RGB	85 Hz
640 × 480	DVI-D	RGB	85 Hz

The multi-format video decoder digitizes images grabbed in YPbPr, Y/C, or CVBS images into YUV16 (YUYV); analog RGB images are digitized into RGB888. After digitizing the analog video, the multi-format video decoder can use its programmable color space converter for converting grabbed images to a different format. The color space converter can convert SD video input into RGB888, YUV16 (YUYV), or YCbCr601; when grabbing high-definition (HD) video, it can convert the video input to RGB888, YUV16 (YUYV), or YCbCr709. The equations for color space conversion are described in the following table:

Color space conversion	Equations
RGB-to-YCbCr601(SD)	<ul style="list-style-type: none"> • $Y = 0.257R + 0.504G + 0.098B + 16$ • $Cb = -0.148R - 0.291G + 0.439B + 128$ • $Cr = 0.439R - 0.368G - 0.071B + 128$
RGB-to-YCbCr709 (HD)	<ul style="list-style-type: none"> • $Y = 0.183R + 0.614G + 0.062B + 16$ • $Cb = -0.100R - 0.339G + 0.439B + 128$ • $Cr = 0.439R - 0.399G - 0.040B + 128$
YUV16-to-YCbCr601 (SD)	<ul style="list-style-type: none"> • $Y = 0.859Y + 15.995$ • $Cb = 0.878U + 15.569$ • $Cr = 0.878V + 15.560$
YUV-to-YCbCr709 (HD)	<ul style="list-style-type: none"> • $Y = 0.859Y - 0.102U - 0.183V + 52.366$ • $Cb = 0.895U + 0.102V + 0.580$ • $Cr = 0.066U + 0.902V + 4.294$
RGB888-to-YUV16	<ul style="list-style-type: none"> • $Y = 0.299R + 0.587G + 0.114B$ • $U = -0.169R - 0.331G + 0.500B + 128$ • $V = 0.500R - 0.419G - 0.081B + 128$

When grabbing video in SDI formats using the multi-rate deserializer, standard definition (SD) video input is digitized into YCbCr601; high-definition (HD) video input is digitized into YCbCr709. There is no color space converter available when grabbing video using the multi-rate deserializer.

Display features

Matrox Orion HD can output video (the operating system's desktop) to four independent display devices simultaneously. These devices can be either digital (DVI-D or SDI) or analog output devices, depending on the connector to which they are connected. The video outputs are not only independent from each other, but are also independent from the video inputs for maximum configuration flexibility. The video outputs can be used to display an extended Windows desktop or the Windows desktop and an exclusive display. However, to grab with the Matrox Orion HD board, one of the board's outputs must be used to display the Windows desktop; otherwise, the Matrox GPU won't be initialized properly and won't be available to control the grab. The table below summarizes the supported standard display resolutions:

Standard display resolution	Transmission standard	Supported in DVI-D format	Supported in SDI format	Supported in analog RGB format	Maximum refresh rate
1920 × 1200		Yes	No	No	60 Hz
1920 × 1080	1080i at 60 frames/sec	No	Yes	No	60 Hz
	1080p at 60 frames/sec	Yes	Yes	Yes	60 Hz
1600 × 1200		Yes	No	Yes	60 Hz
1280 × 1024		Yes	No	Yes	75 Hz
1280 × 720	720p at 60 frames/sec	Yes	Yes	Yes	60 Hz
1024 × 768		Yes	No	Yes	85 Hz
800 × 600		Yes	No	Yes	85 Hz
720 × 576 (non-square pixels)	576i at 25 frames/sec (PAL)	No	Yes	No	50 Hz
720 × 486 (non-square pixels)	486i at 30 frames/sec (NTSC)	No	Yes	No	60 Hz
640 × 480		Yes	No	Yes	85 Hz

Two of the video outputs can be output in SDI format using a multi-rate serializer. The other two video outputs can be output in RGB analog format or in DVI-D format using a multi-format transmitter.

Memory

As a standard feature, Matrox Orion HD has 1 Gbyte of linearly addressable DDR2 SDRAM, used as acquisition and display memory, with a bandwidth of up to 500 MHz, and a 64-bit data bus. This memory is mainly used by the GPU for video display. Some of the memory is also used for video acquisition.

Data transfer

A x16 PCIe Host interface provides Matrox Orion HD with the throughput necessary to handle the transfer of two high-definition video streams to Host memory. Matrox Orion HD's Host interface provides a total peak bandwidth of up to 4.5 Gbytes/sec (that is, 2.5 Gbytes/sec on-board memory to Host and 2.0 Gbytes/sec Host to on-board memory), preventing video data from inadvertently being discarded. In addition, the point-to-point connectivity of PCIe stops other add-in devices from consuming valuable bandwidth between the board and the Host computer.

Limitations of Matrox Orion HD

Certain limitations exist that affect the performance of your Matrox Orion HD board. It is important to be aware of these limitations to optimize the performance of your Matrox Orion HD board.

First, you must install the Matrox Orion HD board in your computer before installing the software.

Second, all functionality on the Matrox Orion HD board is controlled by a Matrox-designed GPU and uses MIL GPU services. For the Matrox Orion HD board to work, the GPU must drive the output of the Windows desktop. Otherwise, you will not be able to allocate the board as a MIL system; calling the MIL-Lite function `MsysAlloc()` with `M_SYSTEM_ORION_HD` will fail.

Third, the Matrox Orion HD board has the same limitations as any other DirectX-capable display board or display device. To work properly, Matrox Orion HD requires the underlying Direct3D engine (GPU) to be in an operational state. Some events can cause all Direct3D devices (for example, Matrox Orion HD and other display boards) to transition to a lost device state. While these devices are in a lost device state, some of their on-board capabilities will not be available. For example, you cannot initiate grab or display operations until Matrox Orion HD recovers from the lost device state.

Some well-known events that can cause a Direct3D device to transition into a lost device state are the following. For more information, refer to the DirectX SDK documentation on the MSDN website (specifically, the Lost Devices reference).

- Locking a computer and pressing CTRL-ALT-DEL.
- Another application assuming full-screen operation (such as, a screen saver).
- Changing the display resolution and desktop settings.
- Connecting to the computer using RemoteDesktop.
- Viewing the desktop from a remote client (such as, VNC).

To recover gracefully from a lost device state, MIL and Matrox Orion HD will wait for the event to be over before trying to transition back to an operational state. However, it is highly recommended to avoid situations that lead to a lost device state.

- ❖ Note that, in most cases, if Matrox Orion HD is in the process of grabbing images, the current grab will continue. The grab will only be interrupted if you initiate a remote connection to the computer.
- ❖ Note that Matrox Orion HD only supports DirectX version 9.

Software

To operate Matrox Orion HD, you can use one or more Matrox Imaging software products that supports the board. These are the Matrox Imaging Library (MIL) and its derivatives (for example, MIL-Lite and Matrox Intellicam). All Matrox software is supported under Windows. Consult your software manual for supported versions of the operating system.

MIL MIL is a high-level programming library with an extensive set of optimized functions for image capture, processing, analysis, transfer, compression, display, and archiving. Image processing operations include point-to-point, statistical, spatial filtering, morphological, geometric transformation, and FFT operations. Analysis operations support calibration, are performed with sub-pixel accuracy, and include pattern recognition (normalized grayscale correlation and Geometric Model Finder), blob analysis, edge extraction and analysis, measurement, image registration, metrology, character recognition (template-based and feature-based), code recognition and verification (1D, 2D, and composite code types), bead inspection (continuous strip of material), 3D reconstruction, and color analysis.

MIL applications are easily ported to new Matrox hardware platforms and can be designed to take advantage of multi-processing and multi-threading environments.

MIL-Lite MIL-Lite is a subset of MIL. It includes all the MIL functions for image acquisition, transfer, display control, and archiving. It also allows you to perform processing operations that are typically useful to pre-process grabbed images.

Matrox Intellicam Matrox Intellicam is an interactive Windows program that allows for fast video source interfacing and provides interactive access to all the acquisition features of your Matrox board. Matrox Intellicam also has the ability to create custom digitizer configuration format (DCF) files, which MIL and its derivatives use to interface to specific non-standard video sources. Matrox Intellicam is included with all Matrox Imaging software products.

Essentials to get started

To begin using Matrox Orion HD, you must have a computer with the following:

- An available conventional x16 PCIe* slot.
- Processor with an Intel 32-bit or 64-bit architecture, or equivalent.
- A relatively up-to-date PCIe chipset.
- A proper power supply. Refer to the *Electrical specifications* section in *Appendix B: Technical information*.
- MIL or one of its derivatives. This software should be installed after you install your board.

Matrox does not guarantee compatibility with all computers that have the above specifications. Please consult with your local Matrox Imaging representative, local Matrox Imaging sales office, the Matrox web site, or the Matrox Imaging Customer Support Group at headquarters before using a specific computer.

Consult your software package for other computer requirements (for example, operating system and memory requirements).

*. It is strongly recommended to install Matrox Orion HD into a x16 PCIe slot. You can also install Matrox Orion HD in a x8 PCIe slot that has a mechanical x16 connector; however, the maximum transfer rate between Matrox Orion HD and the Host is reduced by 50%.

Inspecting the Matrox Orion HD package

You should check the contents of your Matrox Orion HD package when you first open it. If something is missing or damaged, contact your Matrox representative.

Standard items

You should receive the following items:

- The Matrox Orion HD board.

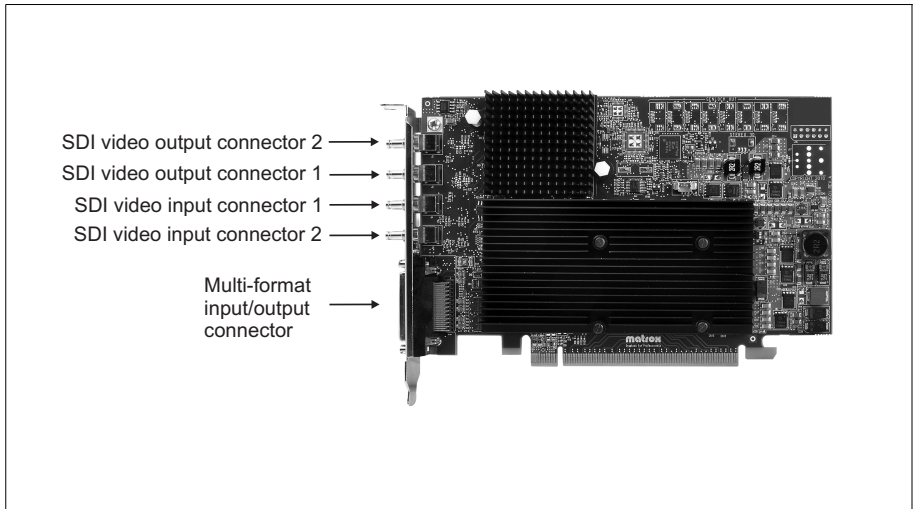

- KX20 to 4 DVI-I cable adapter (two DVI-I connectors for input and two DVI-I connectors for output).

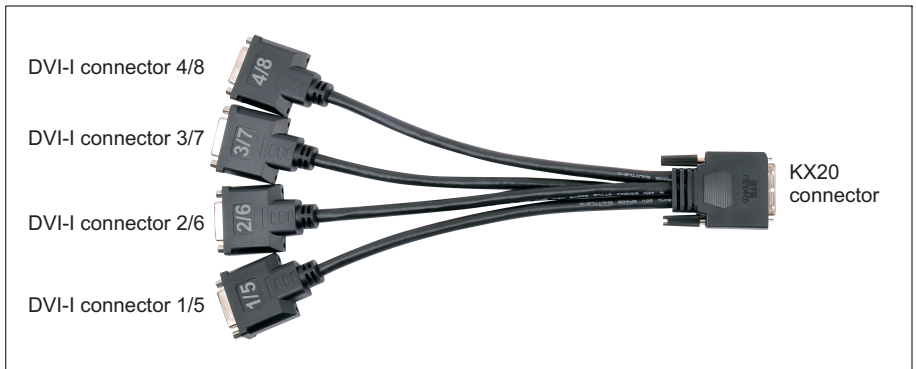

- Four SMB to BNC cable adapters.



- Four DVI to VGA adapters. Note that although the adapters are white in the image below, the color of the adapters you receive might vary.

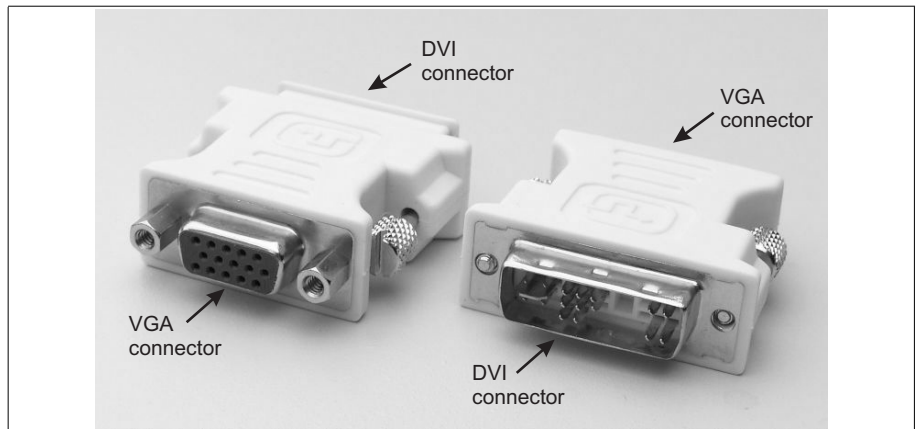

Available separately

You might have also ordered one or more of the following:

- MIL or MIL-Lite. Matrox Intellicam is included with both of these software packages.

Handling components

The electronic circuits in your computer and the circuits on Matrox Orion HD are sensitive to static electricity and surges. Improper handling can seriously damage the circuits. Be sure to drain static electricity from your body by touching a metal fixture (or ground) before you touch any electronic component. In addition, do not let your clothing come in contact with the circuit boards or components.

Warning

Before you add or remove devices from your computer, always **turn off** the power to your computer and all peripherals.

Installation

The installation procedure consists of the following steps:

1. Complete the hardware installation procedure described in *Chapter 2: Hardware installation*.
2. Complete the software installation procedure described in the documentation accompanying your software package.

More information

For information on using multiple Matrox Orion HD boards, refer to *Chapter 3: Using multiple Matrox Orion HD boards*.

For hardware information, as well as environmental and electrical specifications, and connector pinout descriptions, see *Appendix B: Technical information*.

This manual occasionally makes reference to a MIL-Lite function. However, anything that can be accomplished with MIL-Lite can also be accomplished with MIL.

Need help?

If you experience problems during installation or while using this product, refer to the support page on the Matrox Imaging web site: www.matrox.com/imaging/support. This page provides answers to frequently asked questions, as well as offers registered customers additional ways of obtaining support.

If your question is not addressed and you are currently registered with the MIL maintenance program, you can contact technical support. To do so, you should first complete and submit the online Technical Support Request Form, accessible from the above-mentioned page. Once the information is submitted, a Matrox support agent will contact you shortly thereafter by email or phone, depending on the problem.

Chapter

2

Hardware installation

This chapter explains how to install your Matrox Orion HD board in your computer.

Installing your Matrox Orion HD board

Before you install your Matrox Orion HD board, some precautionary measures must be taken. Turn off the power to your computer and its peripherals, and unplug the power cord to drain all standby power. Drain static electricity from your body (by touching a metal part of the computer chassis).

Important

- ❖ Note that your board should be installed before you install your software.

Proceed with the following steps to install your board:

1. Remove the cover from your computer; refer to your computer's documentation for instructions.
2. Check that you have an empty x16 PCIe* slot in which to install your Matrox Orion HD.

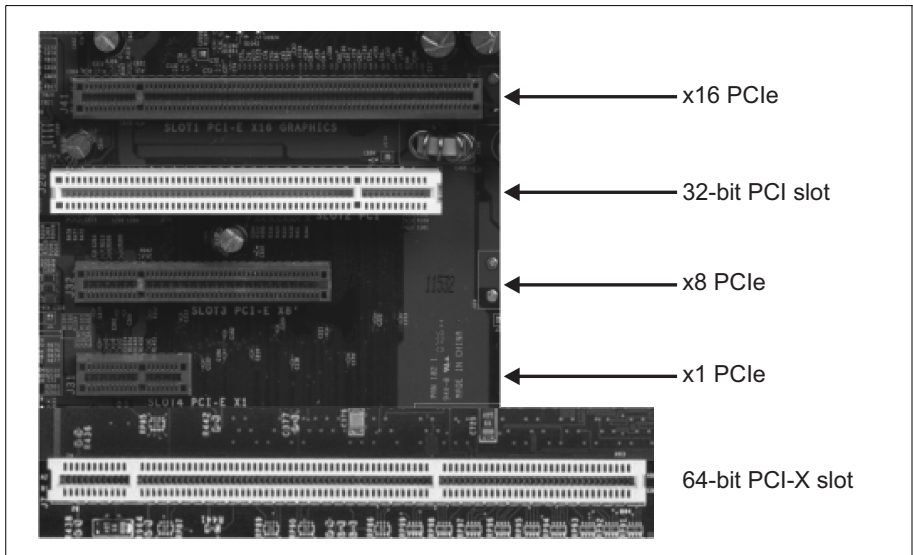

*. It is strongly recommended to install Matrox Orion HD into a x16 PCIe slot. You can also install Matrox Orion HD in a x8 PCIe slot that has a mechanical x16 connector; however, the maximum transfer rate between Matrox Orion HD and the Host is reduced by 50%.

3. If there is a metal plate at the back of the selected slot, remove it. Keep the screw from the top of the plate to anchor your board once it is installed.
4. Position your Matrox Orion HD board in the selected slot, and then press the board firmly but carefully into the connector of the slot.

Important

When installing your Matrox Orion HD board in a x16 PCIe slot, special care must be taken to avoid damaging the board. Some x16 PCIe slots have a connector with a retainer. Matrox Orion HD *must not* come into contact with the latch of this retainer.

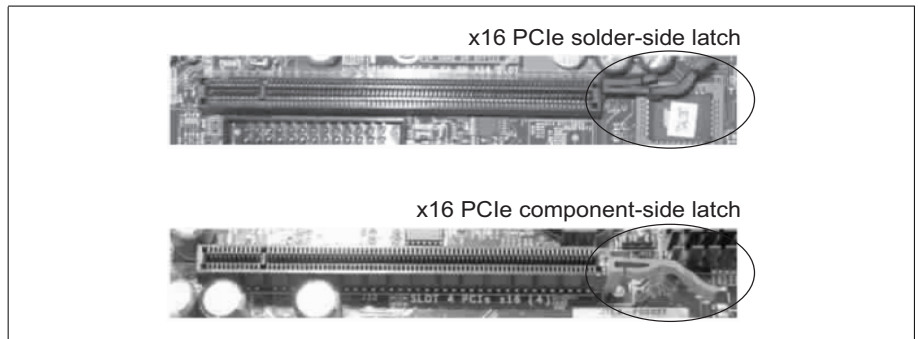

Note that the same is true when removing the board. Alternatively, you can remove the latch from the retainer.

5. Anchor the board using the screw that you removed in step 3.
 6. Replace the cover of your computer.
- Important**
7. Temporarily attach a DVI-D digital display device to the multi-format input/output connector on your Matrox Orion HD board; you must attach it via DVI-I connector 1/5 of the Matrox KX20 to 4 DVI-I cable adapter. For more information on connecting the device, see the *Connecting DVI-D and RGB display devices* sub-section of the *Connecting external devices* section, later in this chapter. Until the Matrox Orion HD driver is installed, a DVI-D digital display device must be temporarily attached so that you can access and view the desktop using the Matrox Orion HD board.
 8. Attach your video sources to your Matrox Orion HD board. See the *Connecting SDI digital video sources* and/or *Connecting video sources of other supported formats* sub-section(s) later in this chapter for more information.

9. Turn on your computer.
 - ❖ When you boot your computer, Windows' Plug-and-Play system will detect a new graphics adapter and you will be asked to assign it a driver. At this point, you should click on **Cancel**. The driver will be installed during the installation of Matrox Orion HD software.
10. Install your Matrox Orion HD software to install the board's driver. Follow on screen instructions.
11. When instructed to reboot your computer, attach any other required display device to your Matrox Orion HD board before rebooting; do not disconnect the temporary DVI-D display device yet, even if you plan on removing it. All the attached display devices must be used to display all or part of your Windows desktop. For more information on connecting devices, see the *Connecting SDI digital display devices* and *Connecting DVI-D and RGB display devices* subsections of the *Connecting external devices* section, later in this chapter.
12. Once you reboot, run Matrox PowerDesk to configure your display settings.
13. Once you exit Matrox PowerDesk, you can remove the temporary DVI-D digital display device if it is not required. Windows will automatically detect that it is no longer present. Note that at least one display device must be attached to your Matrox Orion HD board.
14. Disable active state power management (ASPM) for PCIe devices to maximize the performance of Matrox Orion HD. In the BIOS, disable all ASPM (or equivalent) settings (typically accessible from the **Power management** submenu of the **Advanced Configurations** menu). In addition, in the operating system, disable this option as well. For example, in Microsoft Windows 7, open the **Power Options** dialog box from the **Windows Control Panel**. For the currently selected power plan, click on **Change Plan Settings** and then click on **Change Advanced Power Settings**. In the presented dialog, expand **PCI Express**, and then expand **Link State Power Management** and set it to **Off**.

Connecting external devices

The Matrox Orion HD board has five interface connectors located on its bracket. The interface connectors are used to connect display devices (output) and video sources (input) to the board. Matrox Orion HD can output up to four display devices simultaneously. Similarly, you can connect multiple analog or digital video sources; however, you can acquire data from only two video sources at a time.

Matrox Orion HD bracket interface connectors

The interface connectors on the Matrox Orion HD bracket are as follows:

- **Two SDI video output connectors (SMB).** Used to send two HD/SD 3G-SDI digital video output signals.
- **Two SDI video input connectors (SMB).** Used to receive two HD/SD 3G-SDI digital video input signals.
- **One multi-format input/output connector (KX20).** Used to connect and receive data from two analog or digital video sources and send data to two analog or digital display devices. To interface a device with this connector, you must use the included KX20 to 4 DVI-I cable adapter.

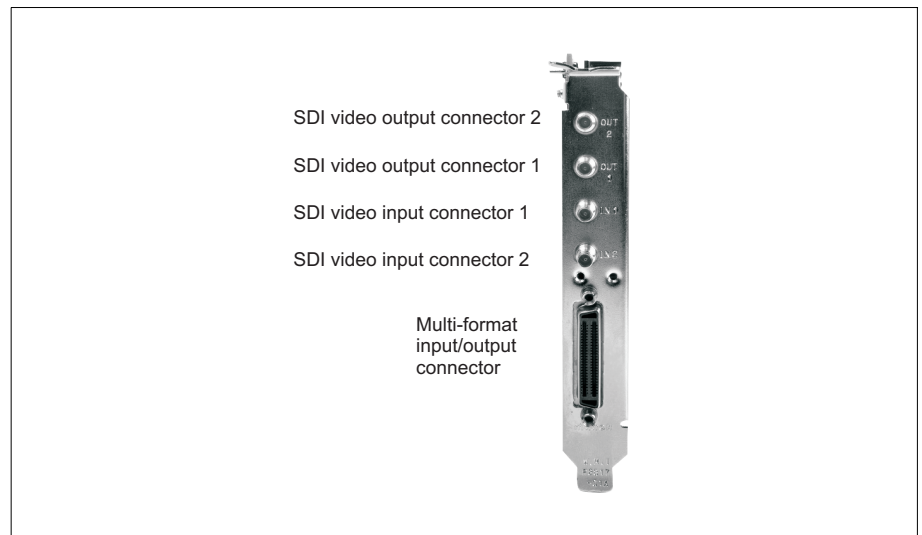

Connecting SDI digital display devices

To connect SDI digital display devices to the SDI video output connectors:

1. Attach the SMB end of the supplied SMB to BNC cable adapter(s) to SDI video output connector(s) 1 and/or 2 on the Matrox Orion HD board. Make sure that the connector on the Matrox Orion HD board is completely inserted in the SMB end of the adapter.
 - ❖ Note that if you need to remove the SMB to BNC cable adapter from the SDI video output connector, you need to pull back on the metal ring of the adapter's SMB connector to release its locking mechanism. Keep the metal ring of the SMB connector pulled back as you pull the cable adapter out.
2. Attach a standard video cable to your display device. As the data rate increases, you should use a shorter cable for a clear signal. This cable is not available from Matrox.
3. Attach your display device's cable to the BNC end of the SMB to BNC cable adapter.

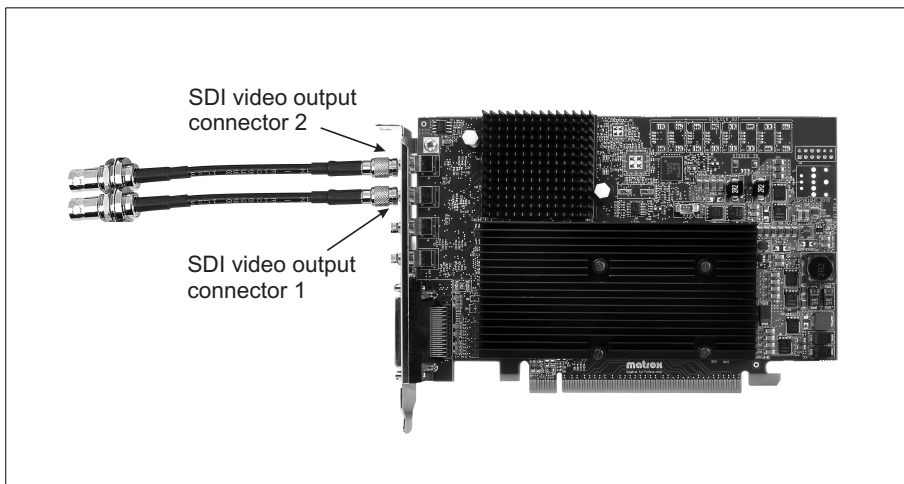

Connecting DVI-D and RGB display devices

To connect DVI-D or RGB display devices to the multi-format input/output connector:

1. Connect the KX20 end of the supplied Matrox KX20 to 4 DVI-I cable adapter to the multi-format input/output connector on the Matrox Orion HD board.

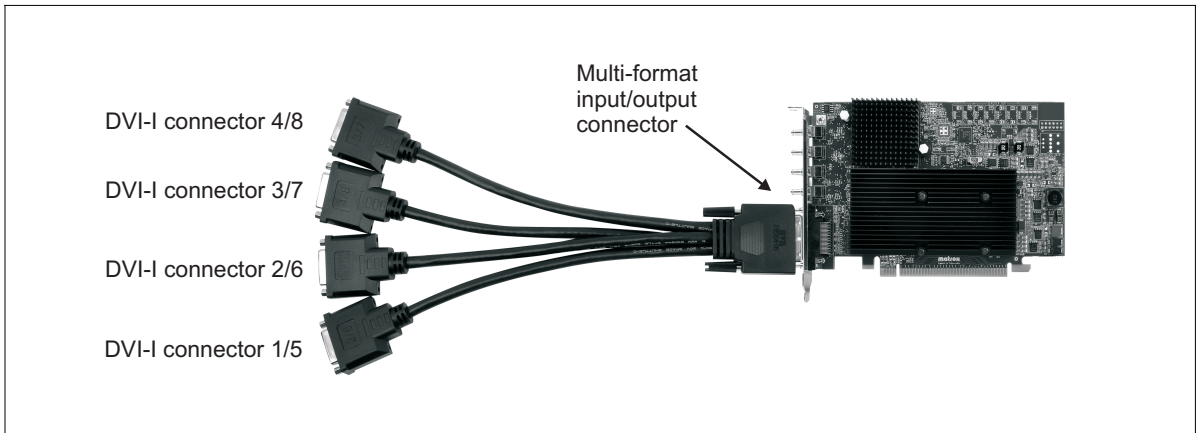

2. Tighten the screws on the sides of the adapter to secure the adapter to the multi-format input/output connector on the Matrox Orion HD board.
3. Connect your display device(s) to DVI-I connector(s) 1/5 and/or 2/6 of the cable adapter. To each of these DVI-I connectors, you can attach a DVI-D display device or an RGB display device.
 - To attach a DVI-D display device to DVI-I connector(s) 1/5 and/or 2/6, you can use a standard DVI cable.

- To attach an RGB display device to DVI-I connector(s) 1/5 and/or 2/6:
 - i. Attach the DVI connector end of the supplied DVI to VGA adapter(s) to DVI-I connector(s) 1/5 and/or 2/6.

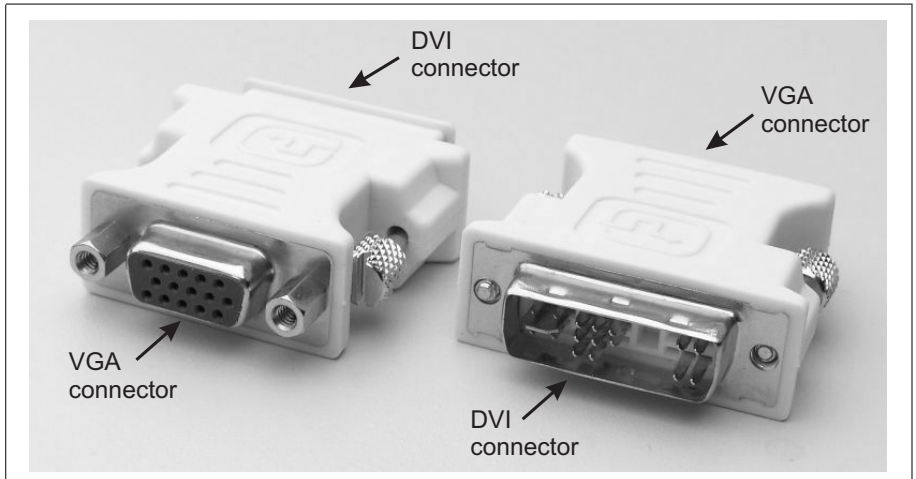

- ii. Tighten the screws on the sides of the adapter to secure the adapter to the DVI-I connector.
 - iii. Attach a standard VGA-compatible video cable to your display device. This cable is not available from Matrox.
 - iv. Attach the VGA connector of the display device's cable directly to the VGA connector end of the DVI to VGA adapter.

Connecting SDI digital video sources

To connect SDI digital video sources to the SDI video input connectors:

1. Attach the SMB end of the supplied SMB to BNC cable adapter(s) to SDI video input connector(s) 1 and/or 2 on the Matrox Orion HD board. Make sure that the connector on the Matrox Orion HD board is completely inserted in the SMB end of the adapter.
 - ❖ Note that if you need to remove the SMB to BNC cable adapter from the SDI video input connector, you need to pull back on the metal ring of the adapter's SMB connector to release its locking mechanism. Keep the metal ring of the SMB connector pulled back as you pull the cable adapter out.
2. Attach a standard video cable to your video source. This cable is not available from Matrox.
3. Attach your video source's cable to the BNC end of the SMB to BNC cable adapter.

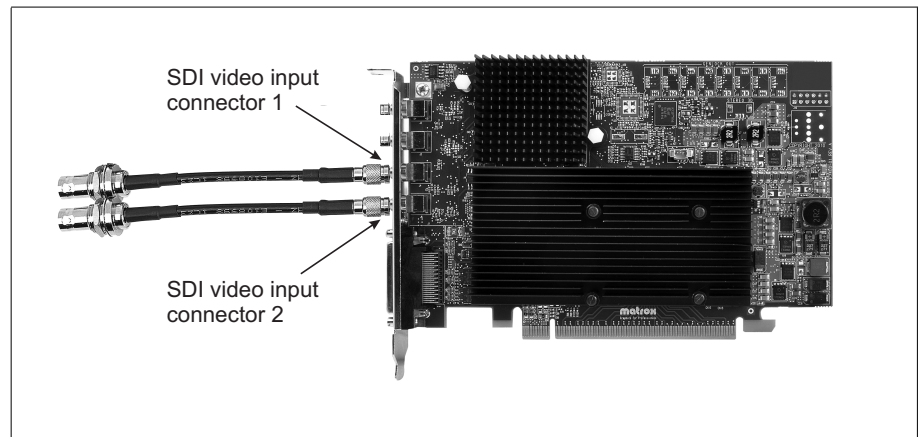

Note that although you can attach more than one video source to Matrox Orion HD, you can only grab from two video sources at a time.

Connecting video sources of other supported formats

To connect DVI-D, RGB, YPbPr, Y/C, and/or CVBS video sources to the multi-format input/output connector:

1. Connect the KX20 end of the supplied Matrox KX20 to 4 DVI-I cable adapter to the multi-format input/output connector on the Matrox Orion HD board.

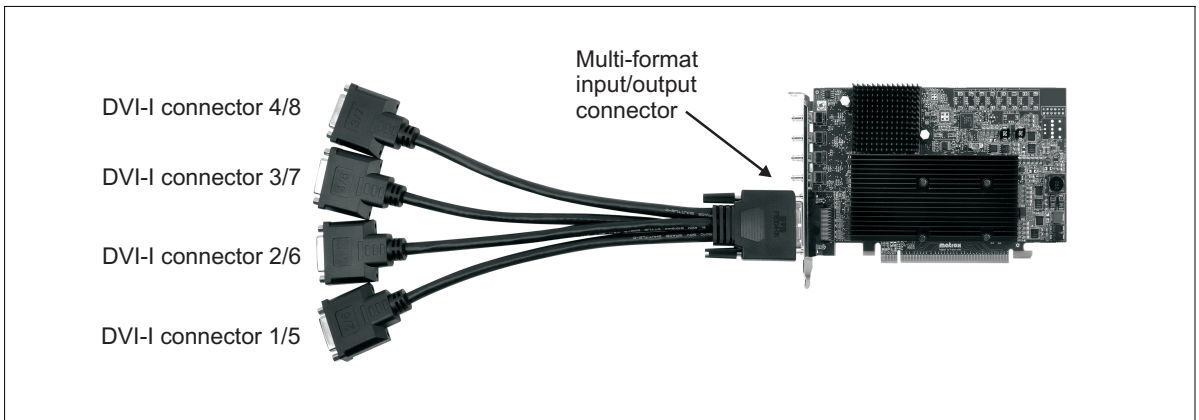

2. Tighten the screws on the sides of the adapter to secure the adapter to the multi-format input/output connector on the Matrox Orion HD board.
3. Connect your video source(s) to DVI-I connector(s) 3/7 and/or 4/8 of the cable adapter. To each of these DVI-I connectors, you can connect one of the following combinations of video sources:
 - DVI-D and/or RGB.
 - DVI-D and/or YPbPr.
 - DVI-D and/or Y/C.
 - DVI-D and/or CVBS/CVBS/CVBS.

This means that to DVI-I connector(s) 3/7 and/or 4/8, you can attach a DVI-D video source, as well as an RGB or YPbPr or Y/C video source, or three CVBS video sources.

- ❖ Note that if you attach video sources to DVI-I connectors 3/7 and 4/8, they don't have to be of the same type.
- To attach only a DVI-D video source to DVI-I connector(s) 3/7 and/or 4/8, you can use a standard DVI cable.
- To attach more than one video source to DVI-I connector(s) 3/7 and/or 4/8, you must use a custom cable. See *Appendix B: Technical information* for information on the DVI-I pin assignment to build a custom cable.
- ❖ Note that although you can attach more than one video source to Matrox Orion HD, you can only grab from two video sources at a time.

Chapter

3

Using multiple Matrox Orion HD boards

This chapter explains how to use multiple Matrox Orion HD boards.

Installation of multiple boards

You can install and use up to four Matrox Orion HD boards in one computer.

Install each additional Matrox Orion HD board as you installed the first board (refer to *Chapter 2: Hardware installation*). The number of Matrox Orion HD boards that you can install is dependent on the number of physical slots in your computer and your BIOS; your BIOS establishes how many PCIe devices can be mapped to the PCIe memory space of your computer. Each board must have at least one of its outputs displaying the Windows desktop; otherwise, the Matrox GPU won't be initialized properly and won't be available to control the grab.

Using MIL-Lite, you have to allocate a MIL system for each board and allocate the resources of each MIL system. For more information, see `MsysAlloc()` with `M_SYSTEM_ORION_HD` in the MIL Reference.

Simultaneous image capture from different boards

Besides simultaneously capturing images from up to two video sources attached to a Matrox Orion HD board, you can simultaneously capture images from video sources attached to different Matrox Orion HD boards.

The use of a high performance PCIe chipset is necessary to sustain PCIe transfers to Host memory. The list of platforms that are known to be compatible with Matrox Orion HD are available on the Matrox web site, under the board's compatibility list.

To measure the effective, available bandwidth of the PCIe interface used by your Matrox Orion HD board, you can use the Orion HD Bench tool integrated in the MILConfig utility. As a reference point, capturing from a 1920 x 1080, BGR32, 60 frames/sec video source will require a minimum bandwidth of 500 Mbytes/sec, plus an additional bandwidth margin of approximately 20%, for a bandwidth of 600 Mbytes/sec.

Appendix A:

Glossary

This appendix defines some of the specialized terms used in the Matrox Orion HD documentation.

Glossary

- **Bandwidth**

A term describing the capacity to transfer data. Greater bandwidth is needed to sustain a higher transfer rate. Greater bandwidth can be achieved, for example, by using a wider bus or by increasing the clock frequency at which an interface or a core operates (for example, increasing the DDR SDRAM clock frequency).

- **BIOS**

Basic Input/Output System. The interface between the operating system and the hardware. It is also responsible for booting the operating system when a unit is turned on.

- **Bus**

A pathway along which signals are sent, generally in two directions, for communication data.

- **Color space**

A color space is a way of representing and describing the complete range of perceived colors. A number of color spaces have been developed. Common color spaces are RGB and HSL. Both describe the same range of colors.

- **CVBS**

Composite Video, Blanking, and Sync. A composite analog video encoding which encodes the luminance and chrominance video components into one signal.

- **DCF**

Digitizer Configuration Format. A file format that defines the input data format and, for example, how to accept or generate video timing signals, such as horizontal sync, vertical sync, and pixel clock.

Such files have a *.def* extension.

- **DDR2 SDRAM**

Double Data Rate2 Synchronous Dynamic Random Access Memory. A type of memory used for image capture and processing. SDRAM allows the Matrox Orion HD to access data at very high speed, which is important for I/O-bound functions.

- **Decoder**

A device which separates the various components of a composite video signal and converts the information into digital format.

- **Deserializer**

A device that converts serial data to parallel data.

- **Digital Visual Interface**

See *DVI*.

- **Digitizer Configuration Format**

See *DCF*.

- **Display memory**

A storage area used for storing data that is being displayed. Since a computer sends out data faster than a screen can display it, the data is temporarily stored in display memory.

- **Driver**

A software program that services an operating system so that the operating system can use a hardware device.

- **DVI**

Digital Visual Interface. A video interface standard designed to provide very high quality on digital display devices or from video sources.

- **Frame**

A single image grabbed from a video source.

- **GPU**

Graphics Processing Unit. The component used to output a visual signal to a display device. It is a specialized microprocessor that offloads and accelerates graphics rendering from the central processing unit (CPU).

- **Grab**

To acquire an image from a video source.

- **Graphics Processing Unit**

See *GPU*.

- **High-definition**

Video format offering high image resolution, typically at 1280x720 (720p) or 1920x1080 (1080i/1080p) pixel resolution, where p is for progressive scanning and i is for interlaced scanning.

- **Horizontal synchronization signal**

The part of a video signal that indicates the end of a line and the start of a new one.

See also *Vertical synchronization signal*.

- **Host**

In general, Host refers to the principal CPU in one's computer.

- **NTSC**

National Television System Committee. An analog interlaced color video format standard, typically at 640 pixels x 480 lines (square pixels) or 720 pixels x 486 lines (non-square pixels) resolution, used in North America and most of South America. In NTSC, 30 frames are transmitted each second. Each frame is made up of 525 individual scan lines (rows). While NTSC has a total of 525 lines, only 480 of these are used for the image data.

- **PAL**

Phase Alternating Line. An analog interlaced color video format standard, typically at 768 pixels x 576 lines (square pixels) or 720 pixels x 576 lines (non-square pixels) resolution, mostly used in Europe. In PAL, 25 frames are transmitted each second. Each frame is made up of 625 individual scan lines (rows). While PAL has a total of 625 lines, only 576 of these are used for the image data.

- **PCIe**

Peripheral Component Interconnect Express. The standard used for the computer bus that acts as an interface between hardware devices, such as Matrox Orion HD, and your computer.

- **RGB**

A color space that represents color using the colors red, green, and blue as components.

- **SDI**

Serial Digital Interface. A standard for digital video transmission over a coaxial cable.

- **Serializer**

A device that takes parallel data, such as an 8-bit signal, and converts it into a serial stream for transmission on a serial link.

- **Standard definition**

Video format offering standard image resolution, typically at 640x480 (480i) pixel resolution.

- **Transmitter**

A device that transmits a signal.

- **Vertical synchronization signal**

The part of a video signal that indicates the end of a frame and the start of a new one.

See also *Horizontal synchronization signal*.

- **VGA**

Video Graphics Array. A basic standard for color resolution in computer monitors that represents the lowest common denominator for compatibility.

- **Y/C**

Luminance/Chrominance. A component video encoding composed of a luminance signal (Y) and a chrominance signal (C). The Y signal provides brightness and contrast. The C signal provides hue information.

- **YCbCr**

A color space used to represent digital component video. YCbCr represents color as brightness and two color difference signals. The Y is the brightness (luma), Cb is the blue minus luma (B-Y), and Cr is the red minus luma (R-Y).

- **YPbPr**

Analog counterpart of YCbCr.

- **YUV**

A color space that represents color using luminance (Y component), hue (U component), and saturation (V component).

Appendix B: Technical information

This appendix contains information that is useful when installing your Matrox Orion HD board.

Board summary

Global information

- Operating system: See software manual for supported versions of Microsoft Windows.

- Minimum computer requirements:
 - x16 PCIe* slot.
 - Processor with an Intel 32-bit or 64-bit architecture, or equivalent.
 - A relatively up-to-date PCIe chipset.
 - A proper power supply. Refer to the *Electrical specifications* section later in this appendix.

Matrox does not guarantee compatibility with all computers that have the above specifications. Please consult with your local Matrox Imaging representative, local Matrox Imaging sales office, the Matrox web site, or the Matrox Imaging Customer Support Group at headquarters before using a specific computer.

*. It is strongly recommended to install Matrox Orion HD into a x16 PCIe slot. You can also install Matrox Orion HD in a x8 PCIe slot that has a mechanical x16 connector; however, the maximum transfer rate between Matrox Orion HD and the Host is reduced by 50%.

Technical features of Matrox Orion HD

- Allows you to acquire data from two independent video sources at a time.
- Allows you to switch between video sources when multiple video sources are connected.
- Supports the following analog video inputs:
 - Standard definition (NTSC/PAL) video input in RGB, CVBS, Y/C, and YPbPr (non-square pixels).
 - High definition video input (720p, 1080i, and 1080p) at up to 60 frames/second in RGB.
 - Video input from display boards (graphics adapters) in standard resolutions (up to 1920 x 1200 at 60 frames/second*) in RGB.
- Supports the following digital video inputs:
 - Standard definition (NTSC/PAL) (non-square pixels) SDI video input.
 - High definition (720p, 1080i, 1080p) DVI-D and SDI video input at up to 60 frames/second.
 - DVI-D video input from display boards (graphics adapters) in standard resolutions (up to 1920 x 1200 at 60 frames/second*).
- When grabbing standard definition (SD), the multi-format video decoder converts the video input into RGB888, YUV16, or YCbCr601; when grabbing high-definition (HD) video, it converts the video input to RGB888, YUV16, or YCbCr709. When grabbing video in SDI format, the data does not get converted; standard definition (SD) video input is received in YCbCr601, and high-definition (HD) video input is received in YCbCr709.

*. Higher frame rates are supported at lower resolutions.

- Allows you to display video output (desktop output) to four display devices independently.
- Supports the following analog video outputs:
 - High definition (720p and 1080p) video output at up to 85 frames/second in RGB.
 - Standard resolutions (up to 1920 x 1080 at 60 frames/second^{*}) in RGB.
- Supports the following digital video outputs:
 - Standard definition (NTSC/PAL) (non-square pixels) SDI video output.
 - High definition (720p, 1080i, and 1080p) DVI-D and SDI video output at up to 60 frames/second. (1080i is only supported in SDI format.)
 - DVI-D video output in standard resolutions (up to 1920 x 1200 at 60 frames/second^{*}).
- 1 Gbyte DDR2 SDRAM used as acquisition and display memory.

*. Higher frame rates are supported at lower resolutions.

Electrical specifications

The following table shows the Matrox Orion HD board's electrical specifications.

Matrox Orion HD	
Operating voltage and current	Typical: 3.3 V, 4.3 mA = 0.014 W Typical 12.0 V, 1.32 A = 15.84 W Total (typical) = 15.85 W +5 V Monitor stand-by power: 750 mA (for all DVI output connectors combined)

Dimensions and environmental specifications

Matrox Orion HD has the following dimensions and environmental specifications:

- Dimensions: 167.65 mm x 111.15 mm x 18.0 mm (6.6 in x 4.4 in x 0.7 in) from bottom edge of goldfinger to top edge of board.
- Minimum/maximum ambient operating temperature: 0 °C to 55 °C (32°F to 131°F).
- Minimum/maximum storage temperature: -40°C to 75°C (-40°F to 167°F).
- Operating relative humidity: up to 95% relative humidity (non-condensing).
- Storage humidity: up to 95% relative humidity (non-condensing).

Connectors on Matrox Orion HD boards

The Matrox Orion HD board has five interface connectors on its bracket. There are two SDI video output connectors, two SDI video input connectors, and one multi-format input/output connector.

The following image shows the Matrox Orion HD bracket and the Matrox Orion HD board.

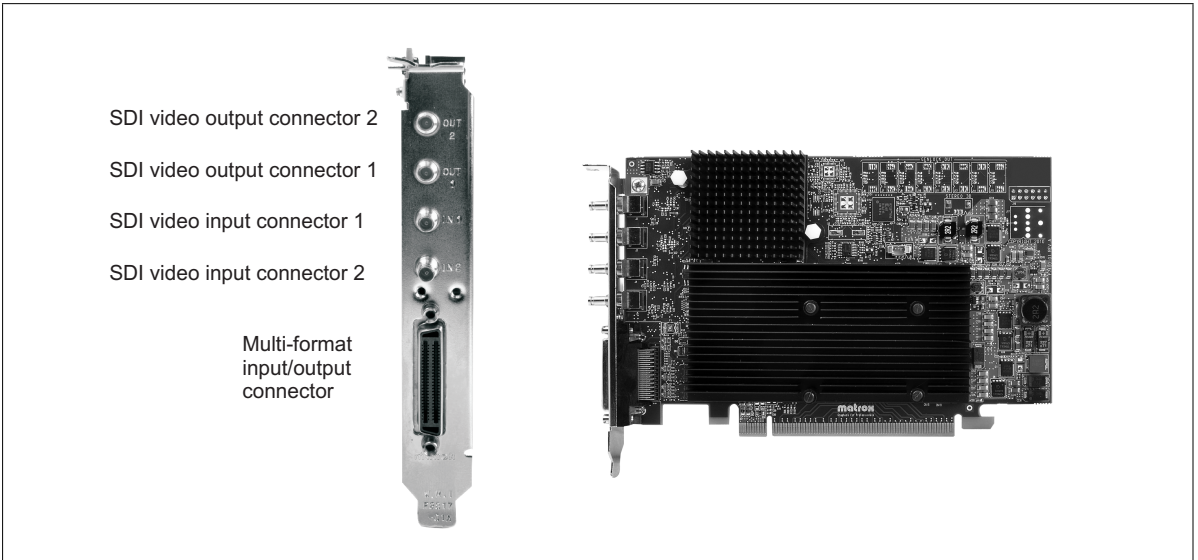

SDI video output connectors

The SDI video output connectors on the Matrox Orion HD board are SMB connectors, used to send HD/SD 3G-SDI video signals. Each connector can output a different video stream. The SDI video output connectors need to be connected to SMB to BNC cable adapters. The BNC connectors on these adapters are high-quality BNC connectors. The SMB to BNC cable adapters connected to the Matrox Orion HD board and the BNC output connectors on the SMB to BNC cable adapters are shown in the following image.

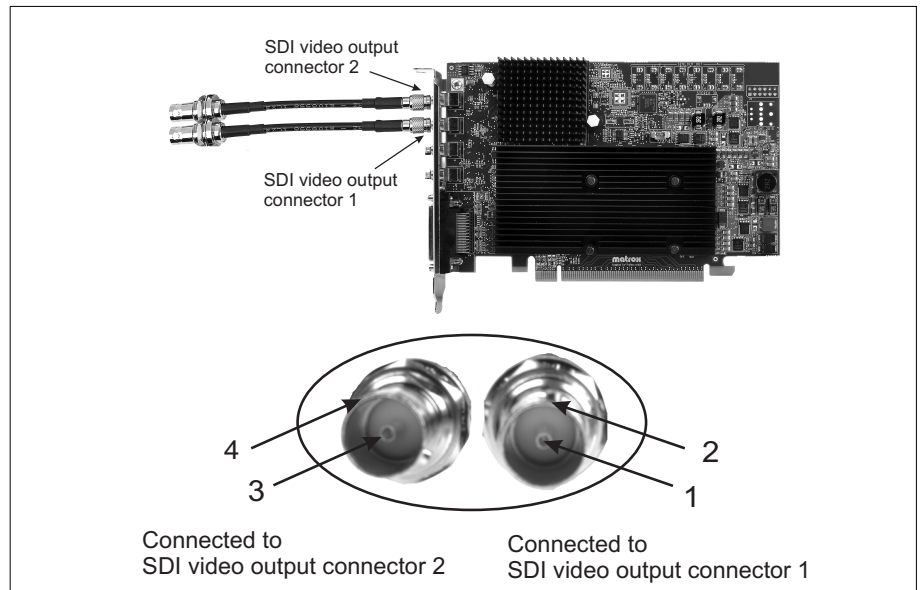

Their pin assignment is as follows:

Pin	Signal	Description
1	HD/SD_SDI_OUT0	High definition or standard definition serial digital video output 0.
2 (SHELL)	GND	Ground.
3	HD/SD_SDI_OUT1	High definition or standard definition serial digital video output 1.
4 (SHELL)	GND	Ground.

You can use a standard BNC-to-BNC video cable (available from your local electronics store) to interface an HD/SD 3G-SDI video source with one of these connectors. If the cable has to be longer than normal, you will need a very good cable to prevent loss. As the data rate increases, you should use a shorter cable for a clear signal.

SDI video input connectors

The two SDI video input connectors on the Matrox Orion HD board are SMB connectors, used to receive HD/SD 3G-SDI video signals. Each connector can receive a different video stream. The SDI video input connectors need to be connected to SMB to BNC cable adapters. The BNC connectors on these adapters are high-quality BNC connectors. The SMB to BNC cable adapters connected to the Matrox Orion HD board and the BNC input connectors on the SMB to BNC cable adapters are shown in the following image.

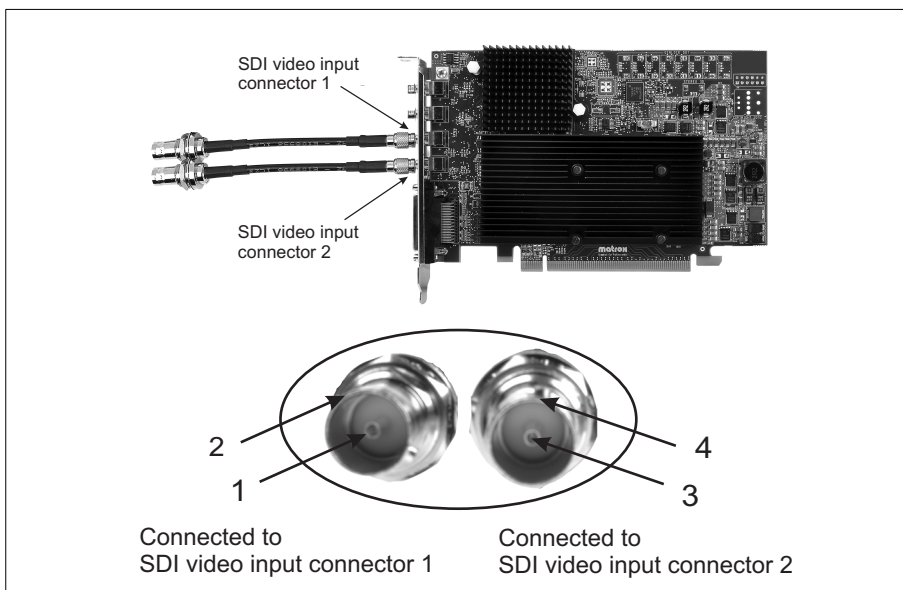

Their pin assignment is as follows:

Pin	Signal	Description
1	HD/SD_SDI_IN0	High definition or standard definition serial digital video input 0.
2 (SHELL)	GND	Ground.
3	HD/SD_SDI_IN1	High definition or standard definition serial digital video input 1.
4 (SHELL)	GND	Ground.

You can use a standard BNC-to-BNC video cable (available from your local electronics store) to interface an HD/SD 3G-SDI video source with one of these connectors. If the cable has to be longer than normal, you will need a very good cable to prevent loss. As the data rate increases, you should use a shorter cable for a clear signal.

Multi-format input/output connector and the Matrox KX20 to 4 DVI-I cable adapter

The multi-format input/output connector on the Matrox Orion HD board is a high-density KX20 connector that allows you to acquire images from a video source and/or display the Windows desktop on a display device. This connector needs to be connected to the Matrox KX20 to 4 DVI-I cable adapter. The Matrox KX20 to 4 DVI-I cable adapter is a high-quality fan-out video cable. It has four DVI-I connectors on one end and a KX20 connector on the other end. Each DVI-I input connector receives different video streams.

The Matrox KX20 to 4 DVI-I cable adapter connected to the Matrox Orion HD board and the DVI-I input and output connectors on the Matrox KX20 to 4 DVI-I cable adapter are shown in the following image.

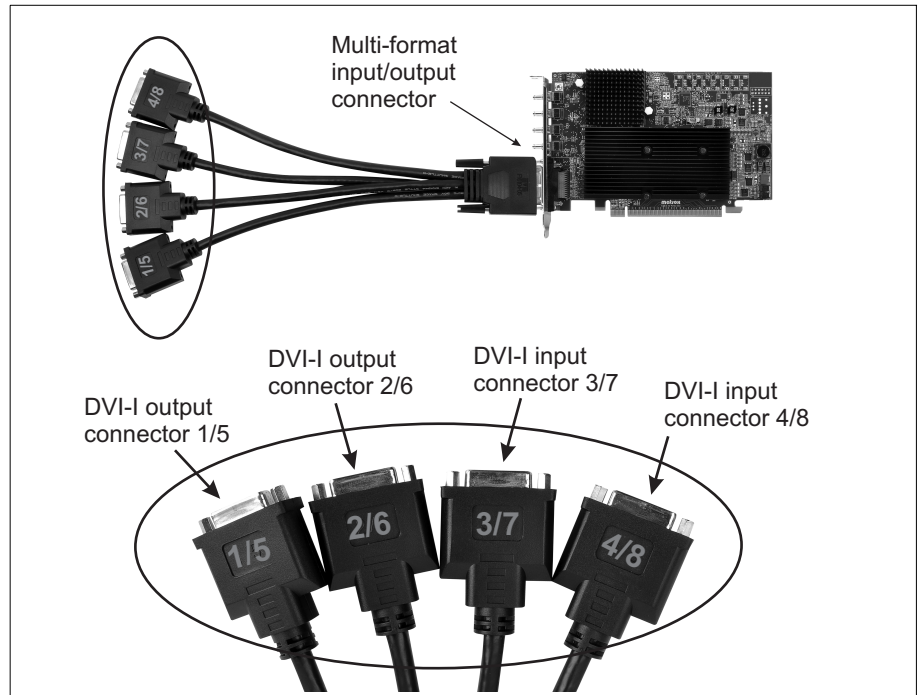

DVI-I connectors 1/5 and 2/6 (multi-format output)

DVI-I connectors 1/5 and 2/6 are output connectors. A DVI-I connector is shown in the following image:

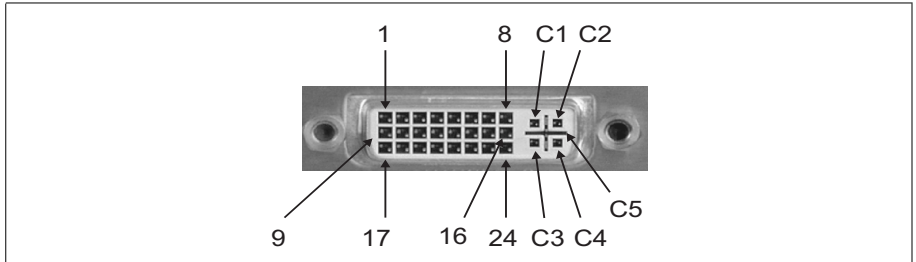

The pin assignment for output DVI-I connectors 1/5 and 2/6 is as follows:

Pin	Signal	Description	Pin	Signal	Description
1	TMDS Data 2-	Digital output red - (link 1).	16	Hot Plug Detect	Enables detection of a display device.
2	TMDS Data 2+	Digital output red + (link 1).	17	TMDS Data 0-	Digital output blue - (link 1) and digital sync output.
3	Ground	Ground for pin 1 and 2.	18	TMDS Data 0+	Digital output blue + (link 1) and digital sync output.
4	TMDS Data 4-	Digital output green - (link 2).	19	Ground	Ground for pin 17 and 18.
5	TMDS Data 4+	Digital output green + (link 2).	20	TMDS Data 5-	Digital output red - (link 2).
6	DDC Clock [SCL]	Serial clock display data output channel.	21	TMDS Data 5+	Digital output red + (link 2).
7	DDC Data [SDA]	Serial data line display data output channel.	22	Ground	Ground for pin 20 and 21.
8	Analog vertical sync	Indicates end of frame and start of new frame (for output).	23	TMDS Clock +	Digital output clock + (links 1 and 2).
9	TMDS Data 1-	Digital output green - (link 1).	24	TMDS Clock -	Digital output clock - (links 1 and 2).
10	TMDS Data 1+	Digital output green + (link 1).	C1	Analog red	R output.
11	Ground	Ground for pin 9 and 10.	C2	Analog green	G output.
12	TMDS Data 3-	Digital output blue - (link 2).	C3	Analog blue	B output.
13	TMDS Data 3+	Digital output blue + (link 2).	C4	Analog horizontal sync	Indicates end of line and start of new line (for output).
14	+5 V Power	Power for monitor when in standby. See the <i>Electrical specifications</i> section earlier in this appendix for more details.	C5	Analog ground	Ground for R, G, and B output signals.
15	Ground	Ground for +5 V Power.			

DVI-I connectors 3/7 and 4/8 (multi-format input)

DVI-I connectors 3/7 and 4/8 are input connectors. A DVI-I connector is shown in the following image:

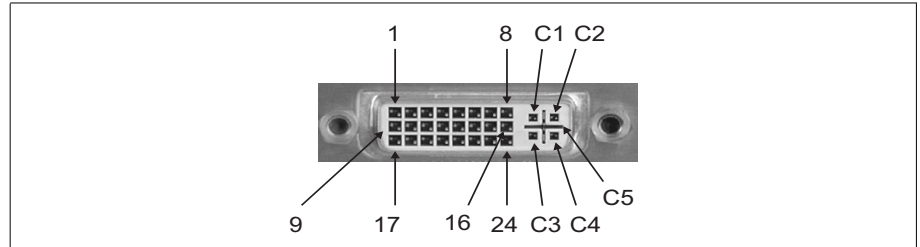

The pin assignment for input DVI-I connectors 3/7 and 4/8 is as follows:

Pin	Signal	Description	Pin	Signal	Description
1	TMDS Data 2-	Digital input red - (link 1).	16	Hot Plug Detect	Enables detection of a video source.
2	TMDS Data 2+	Digital input red + (link 1).	17	TMDS Data 0-	Digital input blue - (link 1) and digital sync input.
3	Ground	Ground for pin 1 and 2.	18	TMDS Data 0+	Digital input blue + (link 1) and digital sync input.
4	TMDS Data 4-	Digital input green - (link 2).	19	Ground	Ground for pin 17 and 18.
5	TMDS Data 4+	Digital input green + (link 2).	20	TMDS Data 5-	Digital input red - (link 2).
6	DDC Clock [SCL]	Serial clock (output). Matrox Orion HD outputs its clock to the input device.	21	TMDS Data 5+	Digital input red + (link 2).
7	DDC Data [SDA]	Serial data line (output). Matrox Orion HD outputs identification data (such as supported resolutions) in EDID format, to the input device.	22	Ground	Ground for pin 20 and 21.
8	Analog vertical sync	Indicates end of frame and start of new frame (for input).	23	TMDS Clock +	Digital input clock + (links 1 and 2).
9	TMDS Data 1-	Digital input green - (link 1).	24	TMDS Clock -	Digital input clock - (links 1 and 2).
10	TMDS Data 1+	Digital input green + (link 1).	C1	Analog red	R or Pr or CVBS2 input.
11	Ground	Ground for pin 9 and 10.	C2	Analog green	G or Y or CVBS0 input.
12	TMDS Data 3-	Digital input blue - (link 2).	C3	Analog blue	B or Pb or C or CVBS1 input.
13	TMDS Data 3+	Digital input blue + (link 2)	C4	Analog horizontal sync	Indicates end of line and start of new line (for input).
14	+5 V Power	Power supply for identification data EEPROM on Matrox Orion HD. Incoming current is also used to see if an input device is connected.	C5	Analog ground	Ground for R, G, and B input signals.
15	Ground	Ground for +5 V Power.			

Appendix C: Major revisions of Matrox Orion HD boards

This appendix lists the major revisions of the Matrox Orion HD boards.

Major revisions of Matrox Orion HD

Versions of Matrox Orion HD		
Part number	Version	Description
OHD1G2S*	103	First shipping version.
	203	Supports hot plug detection for input connections.
	204	Changed KX20 input connector on PCB.

Index

A

- acquisition
 - features 7
 - video formats 7
- adapter
 - DVI to VGA 15
 - KX20 to 4 DVI-I 14, 47
 - SMB to BNC 15, 45–46

B

- bandwidth
 - defined 32
 - effective 30
- BIOS
 - defined 32
- BNC
 - adapter 15, 45–46
 - connector
 - input 46
 - output 45
 - pin assignment
 - input 46
 - output 45
- bus
 - defined 32

C

- cable adapter
 - KX20 to 4 DVI-I 14, 47
 - SMB to BNC 15
- color space
 - defined 32
- components
 - handling 15
 - static electricity 15
- computer requirements 13
- connecting
 - display devices
 - DVI-D 23
 - RGB 24
 - SDI 22
 - external devices 21

- video sources
 - CVBS 26
 - DVI-D 27
 - RGB 26
 - SDI 25
 - Y/C 26
 - YPbPr 26
- connector
 - input
 - BNC 46
 - DVI-I 26, 49
 - SMB 21, 46
 - input/output
 - KX20 21, 47
 - multi-format 21, 47
 - output
 - BNC 45
 - DVI-I 23, 48
 - SMB 21, 45
- CVBS
 - defined 32
 - video sources 26, 41

D

- data transfer 10
- DCF
 - defined 32
- DDR2 SDRAM
 - defined 33
- decoder
 - defined 33
 - multi-format 7–8, 41
- deserializer
 - defined 33
 - multi-rate 7
- display devices
 - connecting
 - DVI-D 23
 - RGB 24
 - SDI 22
 - formats supported 23
- display features 9
- display memory
 - defined 33
 - Matrox Orion HD 9
- driver
 - defined 33

- DVI
 - defined 33
 - to VGA adapter 15
- DVI-D
 - display devices 23
 - video sources 27
- DVI-I
 - connector
 - input 26, 49
 - output 23, 48
 - pin assignment
 - input 49
 - output 48

- E**
 - electrical specifications 43
 - external devices
 - connecting 21

- F**
 - frame
 - defined 34

- G**
 - global information 40–41
 - GPU
 - defined 34
 - grab
 - defined 34

- H**
 - handling
 - components 15
 - hardware
 - installation 18
 - high-definition
 - defined 34
 - horizontal synchronization
 - defined 34
 - host
 - defined 34
 - interface 10

- I**
 - input/output
 - multi-format connector 47
 - installation
 - hardware 18
 - help 16
 - multiple boards 30
 - overview 16

- K**
 - KX20
 - input/output connector 21
 - KX20 to 4 DVI-I
 - cable adapter 47

- L**
 - limitations
 - Matrox Orion HD board 10–11

- M**
 - Matrox Intellicam 12, 15
 - Matrox Orion HD
 - acquisition 7
 - Bench tool 30
 - board 14, 44
 - computer requirements 13
 - connectors 44
 - contents 14
 - data transfer 10
 - dimensions 43
 - display features 9
 - electrical specifications 43
 - limitations 10–11
 - major revisions 52
 - memory 9
 - overview 6
 - precautions 19
 - specifications 43
 - MIL 12, 15
 - MIL-Lite 12, 15

- multi-format
 - connector pin assignment
 - input 49
 - output 48
 - decoder 8, 41
 - input/output connector 21, 47
 - transmitter 9
- multiple boards 30

N

- NTSC
 - defined 35

O

- overview
 - installation 16
 - Matrox Orion HD 6

P

- PAL
 - defined 35
- PCIe
 - defined 35
 - slot 18
- pin assignment
 - input
 - BNC 46
 - DVI-I 49
 - multi-format 49
 - SDI 46
 - output
 - BNC 45
 - DVI-I 48
 - multi-format 48
 - SDI 45
- precautions
 - Matrox Orion HD 19

R

- requirements
 - computer 13
- RGB
 - defined 35
 - display device 24
 - video sources 26, 41–42

S

- SDI
 - defined 35
 - display devices 22
 - input
 - connector 21, 46
 - pin assignment 46
 - output
 - connector 21, 45
 - pin assignment 45
 - video sources 25
- serializer
 - defined 35
 - multi-rate 9
- SMB
 - adapter 15, 45–46
 - connector
 - input 21, 46
 - output 21, 45
 - software supported 12
 - specifications
 - electrical 43
 - environmental 43
 - technical 40–41
 - standard definition
 - defined 36
 - static electricity
 - draining 15, 18
 - support
 - technical 16

T

- technical specifications 40–41
- transmitter
 - defined 36
 - multi-format 9

V

vertical synchronization
defined 36

VGA
defined 36
to DVI adapter 15

video sources
connecting
CVBS 26
DVI-D 27
RGB 26
SDI 25
Y/C 26
YPbPr 26
formats supported 7, 26

Y

Y/C
defined 36
video sources 26, 41

YCbCr
defined 36

YPbPr
defined 36
video sources 26, 41

YUV
defined 37

Regulatory Compliance

FCC Compliance Statement

Warning

Changes or modifications to these units not expressly approved by the party responsible for the compliance could void the user's authority to operate this equipment.

The use of shielded cables for connections of these devices to other peripherals is required to meet the regulatory requirements.

Note

These devices comply with Part 15 of FCC Rules. Operation is subject to the following two conditions:

1. These devices may not cause harmful interference, and
2. These devices must accept any interference received, including interference that may cause undesired operation.

This equipment has been tested and found to comply with the limits for Class A digital devices, pursuant to Part 15 of the FCC Rules. These limits are designed to provide reasonable protection against harmful interference when the equipment is operated in a commercial environment. This equipment generates, uses, and can radiate radio frequency energy and, if not installed and used in accordance with the instruction manual, may cause harmful interference to radio communications. Operation of these devices in a residential area is likely to cause harmful interference in which case the user will be required to correct the interference at his/her own expense.

Industry Canada Compliance Statement

These digital apparatuses do not exceed the Class A limits for radio noise emission from digital apparatuses set out in the Radio Interference Regulations of Industry Canada.

Ces appareils numériques n'émettent pas de bruits radioélectriques dépassant les limites applicables aux appareils numériques de Classe A prescrites dans le Règlement sur le brouillage radioélectrique édicté par Industrie Canada.

EU Notice (European Union)

WARNING: These are class A products. In a domestic environment these products may cause radio interference in which case the user may be required to take adequate measures.

AVERTISSEMENT: Ces appareils sont des produits informatiques de Classe A. Lorsque ces appareils sont utilisés dans un environnement résidentiel, ces produits peuvent entraîner des interférences radioélectriques. Dans ce cas, l'utilisateur peut être prié de prendre des mesures correctives appropriées.

This device complies with EC Directive 89/336/EEC for Class A digital devices. They have been tested and found to comply with EN55022/CISPR22 and EN55024/CISPR24 when installed in a typical class A compliant host system. It is assumed that these devices will also achieve compliance in any Class A compliant system.

Ces unités sont conformes à la Directive communautaire 89/336/EEC pour les unités numériques de Classe A. Les tests effectués ont prouvé qu'elles sont conformes aux normes EN55022/CISPR22 et EN55024/CISPR24 lorsqu'elles sont installées dans un système hôte typique de la Classe A. On suppose qu'elles présenteront la même compatibilité dans tout système compatible de la Classe A.

Directive on Waste Electrical and Electronic Equipment (WEEE)

Europe

(English) European user's information – Directive on Waste Electrical and Electronic Equipment (WEEE)

Please refer to the Matrox Web site (www.matrox.com/environment/weee) for recycling information.

(Français) Informations aux utilisateurs Européens – Règlementation des déchets d'équipements électriques et électroniques (DEEE)

Se référer au site Web de Matrox (www.matrox.com/environment/weee) pour l'information concernant le recyclage.

(Deutsch) Information für europäische Anwender – Europäische Regelungen zu Elektro- und Elektronikgeräten (WEEE)

Bitte wenden Sie sich an dem Matrox-Website (www.matrox.com/environment/weee) für Recycling Informationen.

(Italiano) Informazioni per gli utenti europei – Direttiva sui rifiuti di apparecchiature elettriche ed elettroniche (RAEE)

Si prega di riferirsi al sito Web Matrox (www.matrox.com/environment/weee) per le informazioni di riciclaggio.



Limited Warranty

Refer to the warranty statement that came with your product.

